

MODEL 6620A

Precision Phasemeter

10Hz to 10MHz



Operating Manual



MODEL 6620

***10Hz to 10MHz
IEEE-488 Programmable
Precision Phasemeter***

Serial No. _____

OPERATING MANUAL

Krohn-Hite Corporation
15 Jonathan Drive, Unit 4
Brockton, MA 02301
Tel: (508) 580-1660, Fax: (508) 583-8989
[*sales@krohn-hite.com*](mailto:sales@krohn-hite.com), [*www.krohn-hite.com*](http://www.krohn-hite.com)

TABLE OF CONTENTS

SECTION

1.0	GENERAL DESCRIPTION	1-1
1.1	Introduction.....	1-1
1.2	Specifications.....	1-1
1.3	Typical Performance.....	1-3
1.4	Factors Affecting Phasemeter Accuracy.....	1-4
1.4.1	Inconsistencies In Meter Reading Near 0°	1-4
1.4.2	Noise Present on The Input Signals.....	1-4
1.4.3	Distortion Present on The Input Signal.....	1-5
2.0	OPERATION	2-1
2.1	Introduction.....	2-1
2.2	Power Requirements	2-1
2.3	Turn-On Procedure	2-1
2.4	Front Panel Controls, Connectors and Indicators.....	2-2
2.5	Rear Panel Controls and Indicators.....	2-3
2.6	Operation	2-4
2.7	Deviation Measurements	2-5
3.0	REMOTE PROGRAMMING.....	3-1
3.1	Introduction	3-1
3.2	GBIB Programming	3-1
3.2.1	Introduction	3-1
3.2.2	Implementation Sub Set.....	3-1
3.2.3	IEEE-488 Address and Line Termination Procedure	3-1
3.2.4	IEEE-488 Bus Data Transfers	3-2
3.2.5	IEEE-488 Standard Commands.....	3-4
3.2.5.1	Multi-Line Messages.....	3-4
3.2.5.2	Polling Commands	3-5
3.2.5.3	Uniline Messages	3-6
3.3	RS-232 Interface.....	3-6
3.3.1	Introduction	3-6
3.3.2	The Cable.....	3-6
3.3.3	Communication Parameter Selection Procedure	3-8
3.3.4	RS-232 Data Transfer.....	3-10
4.0	INCOMING ACCEPTANCE	4-1
4.1	Introduction.....	4-1
4.2	Required Test Equipment	4-1
4.3	Procedure	4-2
4.3.1	Display Calibration.....	4-2
4.3.2	Low Frequency Sinewave Check	4-2
4.3.3	High Frequency Sinewave Check.....	4-2
4.3.4	Quadrature Low Frequency Sinewave Check.....	4-3
4.3.5	Balanced High Frequency Sinewave Check.....	4-3
4.3.6	Balanced Low Frequency Squarewave Check.....	4-4
4.3.7	Balanced High Frequency Squarewave Check.....	4-4
4.3.8	Analog Output Check	4-4
4.3.9	Relative Phase Check	4-4

SECTION 1

GENERAL DESCRIPTION

1.1 INTRODUCTION

The Model 6620 Programmable Precision Phasemeter measures the phase angle between two waveforms of coincident frequency, over a range of 10Hz to 10MHz, with a typical accuracy of 0.02° and a resolution of 0.01°. It will accept a wide range of input signal levels automatically without range switching from 10 millivolts to 320 volts rms, and input waveforms of sine, square, triangle and pulses of >50ns. A 5 digit, LED display provides continuous direct readout of phase angles between 0.00° and 360.00°, or ±180°. These two ranges can be selected either manually or automatically. An analog output provides a dc voltage equal to 10mV/° for use with an external meter or recorder.

The 6620 also provides a RELATIVE measurement mode which allows the monitoring of phase deviations, front panel indicators to indicate a too low/high input voltage range.

The Model 6620 is carefully inspected, aged, and adjusted before shipment, and ready for operation when unpacked. If it has been damaged in shipment, make a claim with the carrier and notify Krohn-Hite immediately.

1.2 SPECIFICATIONS

FREQUENCY RANGE: 10Hz to 10MHz (1Hz optional).

PHASE MODE: Absolute or Relative.

ACCURACY

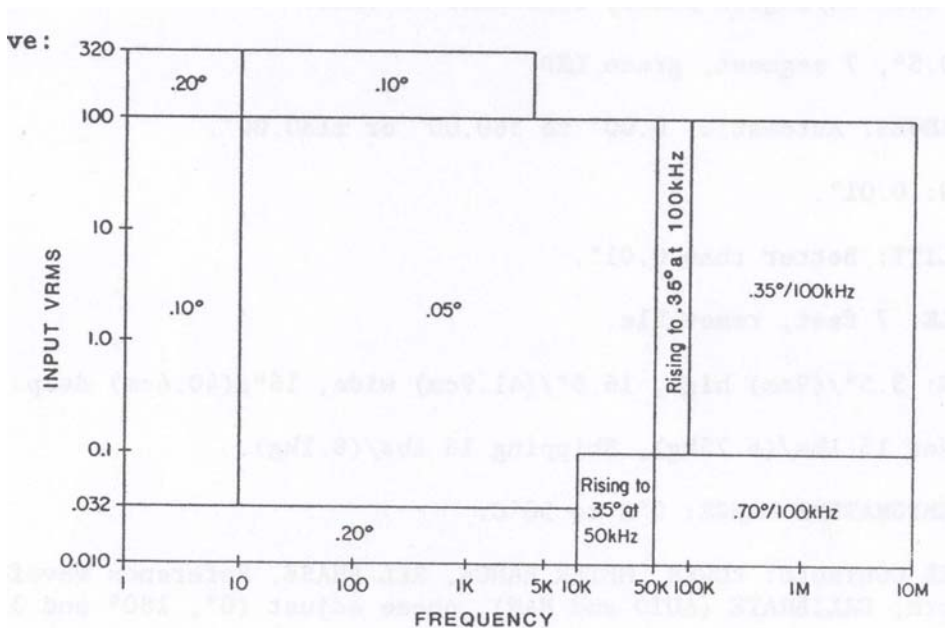

Squarewave: Double Sinewave Specification

INPUT

Signal Amplitude: Auto ranging from 0.01 Volts to 320 volts rms.

Waveforms: Sine, triangle, square and .50ns pulse (The phasemeter is triggered on the positive going transition of the input waveform. Sine wave on the reference input and square wave on the signal input is allowed).

Impedance: 1 Meg ohm in parallel with a 50pf.

Maximum dc Component: ± 200 volts.

RESPONSE

Time Constant: $>10\text{Hz}$, less than 500msec; $<10\text{Hz}$, less than 5sec.

Settling Time: To within specified accuracy; 1 to 8 seconds; dependent on input amplitude and frequency (0.10Hz).

DRIFT

Vs. Time: (30 days without AMC and CALIBRATE reset) Sine Wave, $\pm 0.025^\circ$ from 20Hz to 100kHz; $\pm 0.1^\circ$ at 10Hz; $\pm 0.1^\circ$ per 100kHz above 100kHz. Square Wave, $\pm 0.025^\circ$ from 10Hz to 5kHz; $\pm 0.05^\circ$ to 100kHz; $\pm 0.1^\circ$ per 100kHz above 100kHz.

Vs. Temperature: (Without AMC and CALIBRATE reset) $\pm 0.01^\circ/\text{C}$, 10Hz to 100kHz; $\pm 0.05^\circ/\text{C}$ to 1MHz; $\pm 0.05^\circ/\text{C}$ per MHz above 1MHz.

ANALOG OUTPUT: (for use with an external meter or recorder) 0-3.6 or ± 1.8 volts DC, 10mV DC/degree phase, impedance 50 ohms.

DISPLAY: 0.5", 7 segment, green LED

RESOLUTION; 0.01°

REPEATABILITY: Better than 0.01°

POWER CABLE: 7 feet, removable

DIMENSIONS: 3.5"/(9cm) high, 16.5"/(41.9cm) wide, 16"/(40.6cm) deep.

WEIGHTS: Net 15 lbs/(6.75kg), Shipping 18 lbs/(8.1kg).

AMBIENT TEMPERATURE RANGE: 0°C to 50°C .

FRONT PANEL CONTROLS: POWER, METER RANGE, REL PHASE, Reference Waveform, Signal Waveform, CALIBRATE (AUTO and MAN), phase adjust (0° , 180° and 360°).

POWER REQUIREMENTS: 90-132V or 198-264V, single phase, 50-400Hz, 40W.

OPTIONS

RK-316: Rack Mount Kit for standard 19" rack spacing.

Option 002: 1Hz operation

Option 003: Rear panel BNC connectors, REFERENCE and SIGNAL inputs.

CAB-025: 3ft. BNC Cable

1.3 TYPICAL PERFORMANCE

Typical performance of the Model 6620 is shown in Figure 1.1 with matched inputs. The graph with interrupted lines is the specified response with unmatched inputs over the input range of 0.1 to 100V.

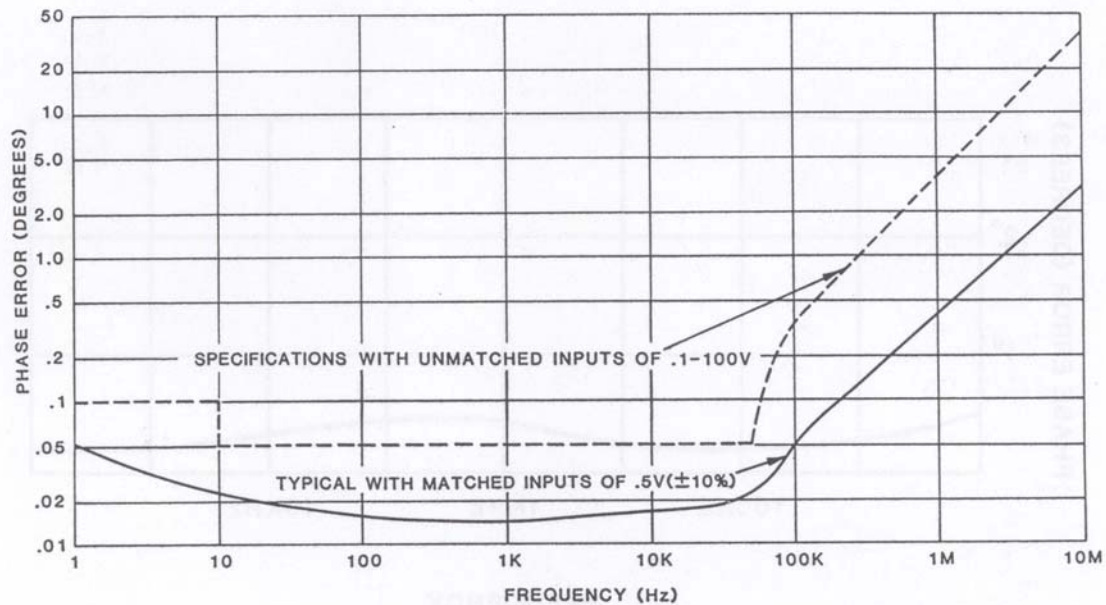

Figure 1.1 Typical Performance

1.4 FACTORS AFFECTING PHASEMETER ACCURACY

1.4.1 Inconsistencies In Meter Reading Near 0° and 360°

A problem affecting a phasemeter's accuracy is the inability of the phasemeter circuit to detect relatively small phase angles, resulting in meter fluctuations or inconsistencies in meter readings. The 6620 overcomes this inconsistency (or ambiguity as it is sometimes referred to) by using a specially designed network that permits measurements as small as 0.01° to be made without meter fluctuations or repeatability errors, and eliminates the need for multiple meter ranges, or shifting of the meter scale.

1.4.2 Noise Present On The Input Signals

Another problem affecting phase accuracy is random noise. If there is a sufficient noise level on either or both inputs, false triggering will occur and a phase error is introduced. The 6620 uses special circuits plus filtering to minimize the effects of noise on the phase accuracy. Typically, any broadband noise present on both inputs 40dB down from the input signals will produce only a 0.05° error. Figure 1.2 gives a typical curve for phase error versus input frequency, for a signal to noise of 10:1 on both inputs.

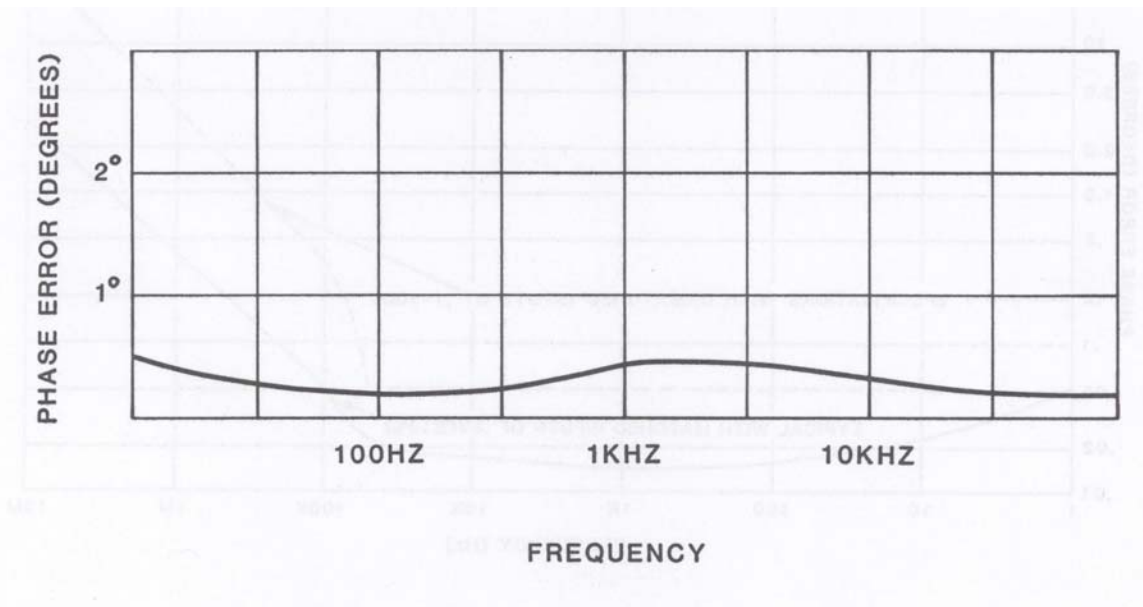

Figure 1.2 Phase Error vs. Random Noise

1.4.3 Distortion Present On The Input Signal

If there is distortion present on one of the signals, a phase error may be introduced, depending upon the relationship between the fundamental and its harmonics. If the amplitude of all the odd or even harmonics add up to zero at the positive zero crossing of the fundamental, then the harmonics will produce no phase error. If the resultant of the amplitudes is not zero, however, it will cause a shift in the zero crossing of the input waveform. Worst case would occur when the maximum of the harmonic coincides with the positive zero crossing of the fundamental. The effect of an even harmonic will not only shift the zero crossing of the waveform, but also alter the symmetry of the comparator or detector output. If a symmetry control loop is added to the phasemeter circuit, the effect of the even harmonic on accuracy can be minimized. The 6620 uses the type of symmetry loop mentioned above.

The effect of an odd order harmonic is not as easily corrected. An odd order harmonic simply shifts the phase of the output of the comparator or detector loop. Since the symmetry is not affected, there is no way to detect any phase error. Figure 1.3 shows the maximum phase error introduced versus the percentage of harmonic distortion present on each input channel.

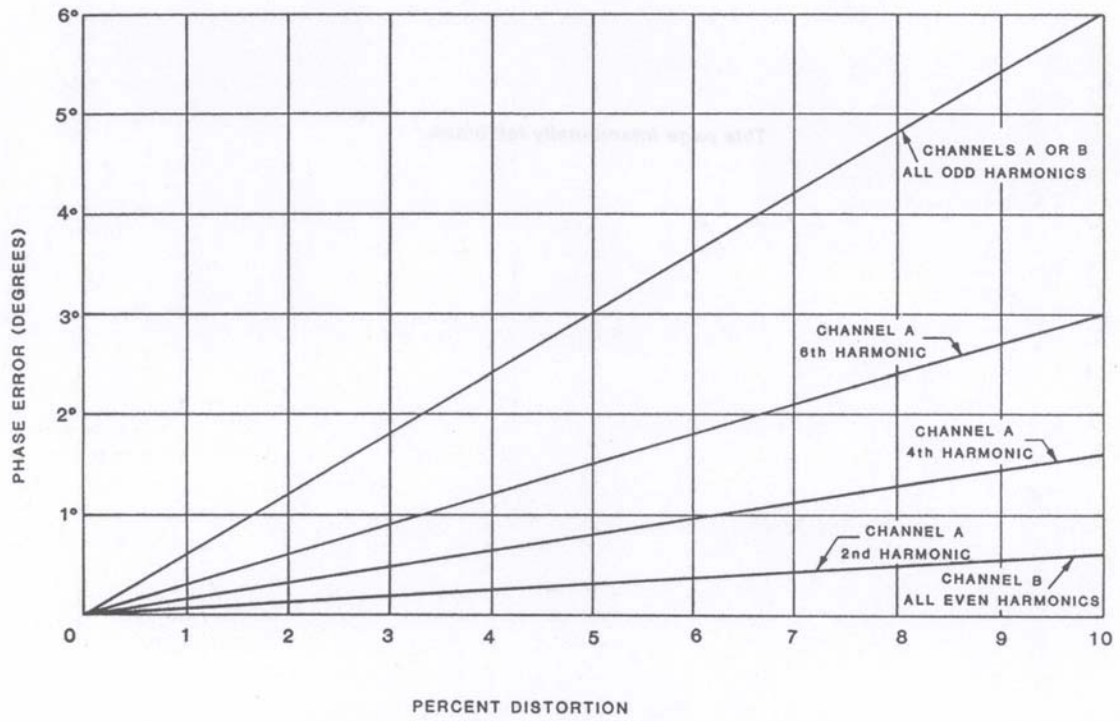

Figure 1.3 Maximum Phase Error vs. % Harmonic Distortion

SECTION 2 OPERATION

2.1 INTRODUCTION

This section describes the basic operation of the Model 6620. It includes the proper ac power requirements, the recommended turn-on procedure and a detailed explanation of all operating controls and modes of operation.

2.2 POWER REQUIREMENTS

The Model 6620 is designed to operate from a single phase, 50–400Hz ac power source of 90–100, 108–132, 198–244 or 216–264 volts. Line switches on the rear panel allow it to be powered from one of the above 4 voltage ranges. The ac power receptacle, on the rear panel, is a standard 3-pin connector and complies with the European I.E.C. standard. The fuse receptacle contains a $\frac{3}{4}$ ampere slo-blow fuse for 120V operation and a $\frac{3}{8}$ ampere slo-blow fuse for 240V operation. A detachable line cord is provided with the instrument.

2.3 TURN-ON PROCEDURE

1. Set the line switches for the correct voltage range and check to see that a fuse with the correct rating is in the fuse receptacle.
For 90-110 volts, set the 120V/240V switch to 120V and the NORM/LO switch to LO. The fuse should be $\frac{3}{4}$ amp.
For 108-132 volts, set the 120V/240V switch to 120V and the NORM/LO switch to NORM. The fuse should be $\frac{3}{4}$ amp.
For 198-244 volts, set the 120V/240V switch to 240V and the NORM/LO switch to LO. The fuse should be $\frac{3}{8}$ amp.
For 216-264 volts, set the 120V/240V switch to 240V and the NORM/LO switch to NORM. The fuse should be $\frac{3}{8}$ amp.
2. Make sure that the POWER switch is in the OFF position.
3. Plug the line cord into the unit and into an ac outlet.
4. Turn the power on and allow it to warm-up for several minutes.

CAUTION
For safety purposes, the line cord must be connected to a grounded 3 terminal ac outlet. Because of potentially dangerous voltages that exist within the unit, the cover should be removed by qualified personnel only.

2.4 FRONT PANEL CONTROLS, CONNECTORS AND INDICATORS

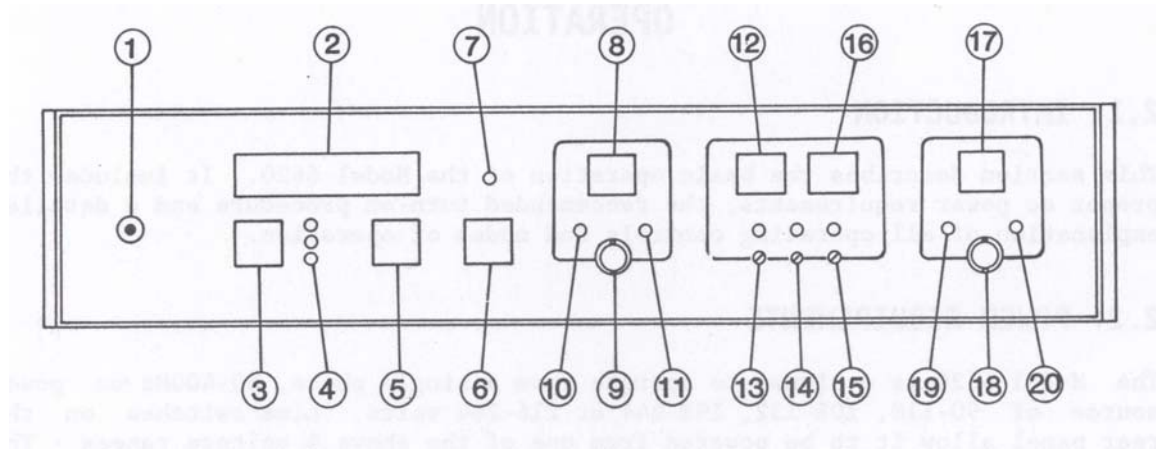

Figure 2.1 Front Panel Controls, Connectors and Indicators

- | | |
|--------------------|---|
| 1. POWER | On/Off toggle switch. |
| 2. DISPLAY | 5 digit, green LED, 0.55" high. |
| 3. DISPLAY RANGE | Selects desired range of AUTO, 0-360°, or ±180°. |
| 4. LED INDICATORS | Indicates display range in use; AUTO, 0-360°, or ±180°. |
| 5. REL PHASE | Selects RELATIVE display mode. When pressed, the DISPLAY will indicate 0.00°. |
| 6. LOCAL | This key has two separate functions. One in remote operation and the other in local operation. <ol style="list-style-type: none"> a. In remote operation, pressing the [LOCAL] key will return the unit to local operation. The LED indicator under REMOTE will turn off. b. In local operation, pressing the [LOCAL] key will display menus for setting GPIB or RS-232 configuration. See Section 3. |
| 7. LED INDICATOR | Indicates REMOTE operation. |
| 8. WAVEFORM | Selects desired waveform applied to REFERENCE input. |
| 9. REFERENCE INPUT | BNC, 10mV to 320Vrms. |
| 10. LED INDICATOR | Indicates REFERENCE input is <10mVrms. |
| 11. LED INDICATOR | Indicates REFERENCE input is >320Vrms. |

- | | |
|----------------------------------|---|
| 12. AUTO | Selects AUTO METER CORRECT (AMC) mode. When pressed, the unit will cycle through and automatically calibrate the display at 0°, 180° and 360°, and respective LED's will light intermittently. This feature will not calibrate the analog output of the unit, only the display. |
| 13. 0° CONTROL & LED INDICATOR | Indicates control for 0° calibration can be adjusted. |
| 14. 180° CONTROL & LED INDICATOR | Indicates control for 180° calibration can be adjusted. |
| 15. 360° CONTROL & LED INDICATOR | Indicates control for 360° calibration can be adjusted. |
| 16. MANUAL | When pressed, the 0° LED indicator will light intermittently. Adjust screwdriver control positioned below 0° LED so DISPLAY indicates 0.00°. When pressed again, the 180° LED indicator will light intermittently. Adjust screwdriver control positioned below 180° LED so that DISPLAY indicates 180.00°. When the 360° adjustment is made in a similar manner, pressing the [MAN] key will return the unit to normal operation. |
| 17. WAVEFORM SELECT | Selects desired waveform applied to the SIGNAL input. |
| 18. SIGNAL INPUT | BNC, 10mV to 320Vrms. |
| 19. LED INDICATOR | Indicates SIGNAL input is <10mVrms. |
| 20. LED INDICATOR | Indicates SIGNAL input is >320Vrms. |

2.5 REAR PANEL CONTROLS AND CONNECTORS

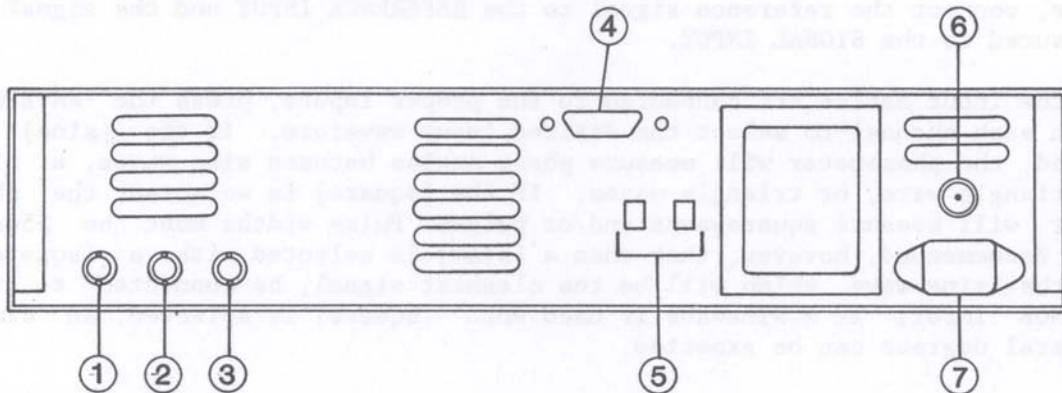

Figure 2.2 Rear Panel Controls and Connectors.

- | | |
|--------------------|----------------------------------|
| 1. SIGNAL INPUT | BNC (optional), 10mV to 320Vrms. |
| 2. REFERENCE INPUT | BNC (optional), 10mV to 320Vrms. |

- | | | |
|----|---------------------|---|
| 3. | ANALOG OUTPUT | BNC, 0 to 3.6Vdc, 10mV/°. Impedance 50 ohms. |
| 4. | IEEE-488 PORT | Standard IEEE-488 interface connector (Uses metric hardware) or optional RS-232 (uses standard hardware). |
| 5. | LINE | Slide switches to select 120V or 240V operation, and NORMAL or LOW ac line. |
| 6. | FUSE RECEPTACLE | ¾ amp for 120V operation, 3/8 amp for 240V operation. |
| 7. | AC POWER RECEPTACLE | Standard 3 Pin Receptacle. |

2.6 OPERATION

To operate the Model 6620 proceed as follows:

1. Make the appropriate power connections to the unit. Turn the power on and let the unit warm up for at least 30 minutes to achieve the rated accuracy and eliminate any drift that may be caused due to temperature variations.
2. Pressing the [MAN] key momentarily again will light the 0° LED indicator intermittently. Adjust the screwdriver control below the LED so DISPLAY indicates 0.00°.

Pressing the [MAN] key momentarily again will light the 180° LED intermittently. Adjust the screwdriver control below the 180° LED so DISPLAY indicates 180.00°.

Pressing the [MAN] key momentarily again will light the 360° LED intermittently. Adjust the screwdriver control below the 360° LED so DISPLAY indicates 360.00°. When the [MAN] key is momentarily pressed, the DISPLAY will return to normal operation.

After the unit has warmed up and the initial calibration was done to the phasemeter, connect the reference signal to the REFERENCE INPUT and the signal to be measured to the SIGNAL INPUT.

When the input cables are connected to the proper inputs, press the WAVEFORM key on each channel to select the desired input waveform. If the [sine] is selected, the phasemeter will measure phase angles between sine waves, a sine and triangle wave, or triangle waves. If the [square] is selected, the phasemeter will measure squarewaves and/or pulses. Pulse widths must be >0ns. It is recommended, however, that when a [sine] is selected with a [square], that the sine wave, which will be the cleanest signal, be connected to the REFERENCE INPUT. If a sinewave is used when [square] is selected, an error of several degrees can be expected.

NOTE

It is recommended that matched, equal length, coaxial cables be used, as a difference in length may affect the phasemeter accuracy, especially at higher frequencies. As an example, two cables of the same type (approximately 30pf/ft), but differing in length by one foot will create an error at 100kHz of about 0.06°.

After selecting the proper WAVEFORM, check to see that the LED above the REFERENCE and SIGNAL inputs are off. When the input voltage is less than 10mV rms (<.01V) or greater than 320V rms (>320V),

the appropriate LED will light to indicate the too low/high condition. If either LED is on, adjust the input voltage level until the LED turns off.

When the input voltages are adjusted to within the limits of the phase meter, select the METER RANGE. There are three modes of operation; AUTO, 0-360°, and ±180°.

1. AUTO
In this mode, the phasemeter will switch ranges automatically between 0-36- or ±180. If the phasemeter is in the 0-360 range, and the phase angle being measured is approaching 10.00° or 350.00°, the phasemeter will automatically switch to the ±180 range. When the ±180° range and the phase angle being measured approaches +170.00° or -170.00°, the phasemeter will automatically switch to the 0-360° range. This feature allows the user to continuously measure phase angles without interruption.

2. 0-360
This range will measure phase angles between approximately -5.00° and 365.00°. For phase angle measurements exceeding 360.00°, the DISPLAY will remain in the 360.00° range until the reading is approximately 365.00°. The phasemeter will then switch to the low end of the range, and the DISPLAY will indicate a phase of approximately 5.00°.

Conversely, if the phase angle being measured is less than 0.00°, the DISPLAY will remain in the 0.00° range until the reading is approximately -5.00°. The phasemeter will then switch to the high end of the range, and the DISPLAY will indicate approximately 355.00°.

3. ±180
This range operates in the same manner as the 0-360° range, and will measure phase angles between approximately -185.00° and +185.00°. For phase angle measurements exceeding +180.00°, the DISPLAY will remain in this range until the phase is approximately +185.00°. The phasemeter will then switch to the -180.00° range and the DISPLAY will indicate approximately -175.00°.

Conversely, if the phase angle being measured exceeds -180.00°, the DISPLAY will remain in the -180.00° range until the reading is approximately -185.00°. The phasemeter will then switch to the +180.00° range, and the DISPLAY will indicate approximately +175.00°.

2.7 DEVIATION MEASUREMENTS

The Model 6620 provides a mode for measuring relative phase deviations. When the [REL PHASE] key is pressed, the phasemeter display will indicate 0.00°. This is the reference point of the phasemeter. When the signal changes in phase, the DISPLAY will indicate phase deviation of the signals being measured.

SECTION 3

REMOTE PROGRAMMING

3.1 INTRODUCTION

The model 6620 is compatible with the IEEE-488 Standard Interface Bus (GPIB) or the Electronic Industries Association (EIA) RS-232C Interface Standard. Section 3.2 is relevant to the IEEE-488 and Section 3.3 defines the RS-232C.

3.2 GPIB PROGRAMMING

3.2.1 Introduction

The Model 6620 remote programming interface accepts both ASCII data commands and IEEE-488 standard commands (ANT true) for control of the unit.

In presenting the information required to program the Model 6620 via the IEEE-488 interface, this manual pre-supposes a user knowledge of both ASCII data and IEEE-488 bus commands.

3.2.2 Implementation Sub Set

IDENTIFICATION AND CAPABILITIES

SH1	Complete source handshake.
AH1	Complete acceptor handshake.
T6	Basic talker, no talk-only mode, talker is un-addressed when unit is addressed to listen.
L4	Basic listener, no listen-only mode, listener is un-listened when unit is addressed to talk.
SR1	Service requested when any out of range condition occurs.
RL1	Complete Remote/Local and Local lockout control.
PP1	Complete parallel poll capabilities.
DC1	Complete device clear capabilities.
DT0	No device trigger.
C0	No controller capability.
E1	Open collector drivers.

3.2.3 IEEE-488 Address and Line Termination Procedure

The GPIB Address is set via the front panel keyboard. When the phasemeter is not in remote operation (LED indicator off), pressing the [LOCAL] key momentarily will display menu 1 for setting the GPIB address (Figure 3.1). Once the menu is displayed, pressing the [METER RANGE] key will increase the address number and pressing the [REL PHASE] key will decrease the address number.

After the GPIB Address is set, pressing the [LOCAL] key momentarily again will display menu 2 for setting the line termination. Once again, pressing the [METER RANGE] key and/or the [REL PHASE] key will select the desired line termination configuration (refer to Figure 3.2 below).

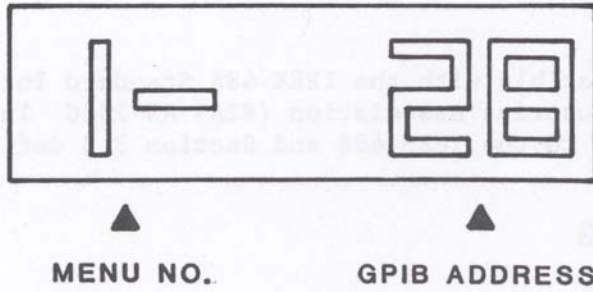

Figure 3.1 GPIB Address

Choices	Description
Cr	Carriage Return
LF	Line Feed
CrLF	Carriage Return/Line Feed
LFcr	Line Feed/Carriage Return
nOnE	No Termination

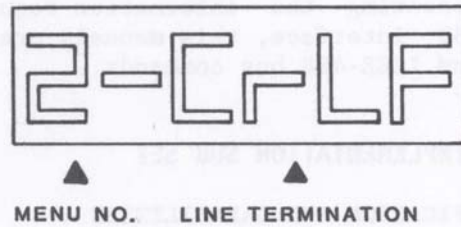

Figure 3.2 Line Termination

3.2.4 IEEE-488 Bus Data Transfers

Receive Commands

The Model 6620 must first receive its primary listen address. This is followed by the desired command. The commands are executed immediately upon receipt. This means no termination character or EOI message is needed, however, these may be sent if desired.

The following chart indicates the ASCII characters that must be received to operate the various controls.

<u>ASCII CODE</u>	<u>CONTROL FUNCTION</u>
M1	Auto Range Mode
M2	360° Range Mode (non-auto)
M3	180° Range Mode (non-auto)
P0	Non-Relative Phase Mode
P1	Relative Phase Mode
R1	Reference Channel = Sine Wave
R2	Reference Channel = Square Wave
S1	Signal Channel = Sine Wave
S2	Signal Channel = Square Wave
T0	No Line Termination
T1	Line Termination = <CR>
T2	Line Termination = <LF>
T3	Line Termination = <CR><LF>
T4	Line Termination = <LF><CR>
Q0	Service Request Off
Q1	Service Request On
Q2	Query Status
C1	Manual 0° Calibration
C2	Manual 180° Calibration
C3	Manual 360° Calibration
C4	Auto Calibration

NOTE: It is necessary to perform an Auto Calibration to leave Manual Calibration mode.

Send Data

The Model 6620 must first receive its primary talk address. It will then send a "space" followed by the data and terminated by the selected line-termination codes. The last character is sent with the EOI line true. The data to be sent is in the front panel display, except after receipt of the "Q2" Query Status command.

The following chart indicates the format of the STATUS data sent by the Model 6620. Position is indicated from left to right, thus, "1-Signal Channel Mode" references the MSD of the status word.

- 1 SIGNAL CHANNEL MODE
 1 = sine wave
 2 = square wave
- 2 SIGNAL CHANNEL ERROR INDICATORS
 0 = signal channel within range (No Error)
 1 = signal channel under range
 2 = signal channel overload error
- 3 REFERENCE CHANNEL MODE
 1 = sine wave
 2 = square wave

- 4 REFERENCE CHANNEL ERROR INDICATORS
 0 = reference channel within range (No Error)
 1 = reference channel under range
 2 = reference channel overload error

- 5 PHASEMETER RANGE INDICATORS
 1 = manual range mode/360° range
 2 = manual range mode/180° range
 3 = auto range mode/360° range
 4 = auto range mode/180° range

- 6 RELATIVE PHASE MODE INDICATOR
 0 = absolute phase mode
 1 = relative phase mode

- 7 CALIBRATION INDICATORS
 0 = no calibration LED's lit
 1 = 0° calibration LED's lit
 2 = 180° calibration LED lit
 3 = 360° calibration LED lit

Device Clear

Since the manual keyboard is capable of leaving the Model 6620 in either the SET GPIB ADDRESS/LINE TERMINATION MODE or a CALIBRATION MODE, the DEVICE CLEAR instruction (DCL) should be employed at the start of a GPIB sequence. DCL will put the instrument into AUTO RANGE/0-360 RANGE, NON-RELATIVE PHASE ANGLE MODE, SIGNAL/REFERENCE CHANNEL SINE WAVE MODE, as well as resetting instrument to PHASE ANGLE DISPLAY and NON-CALIBRATION MODE.

3.2.5 IEEE-488 STANDARD COMMANDS

These commands are sent with ATN true as described in the Standard.

3.2.5.1 MULTI-LINE MESSAGES

<u>IEEE-488 COMMAND</u>	<u>MNEMONIC</u>	<u>RESULT</u>
My Listen Address	MLA	Enables unit to receive data.
Unlisten	UNL	Disables all units from receiving data.
My Talk Address	MTA	Designates unit to send data.
Untalk	UNT	Disables all units from sending data.
Local Lockout	LLO	Disables return to local key on front panel such that only the controller can activate the front panel keyboard.
Go To Local	GTL	Puts unit into local control mode such that front panel keyboard is activated.
Device Clear	DCL	Returns all units to power on conditions.
Selected Device Clear	SDC	Performs same functions as Device Clear (DCL) except only if unit is addressed.

Discussion: (See Section 2.8 and Figure 10 of the IEEE-488 Interface Standard).

Note that there are 4 possible states; local, remote, local-with-lockout and remote-with-lockout. Front panel control is considered to be local, while control from the “bus” is considered to be remote. When the unit is addressed to listen (MLA), it goes into remote. When Go To Local (GTL) is sent, it goes into local. Also, if lockout mode is not set by the controller, local lockout (LLO) command is not sent; pressing the [LOCAL] key will return the unit to local.

Note: The lockout mode is not related to whether control is local or remote, only whether control can be returned to local by the local key.

Lockout mode (local-with-lockout and remote-with-lockout versus local and remote) is controlled by the controller. Sending the Local Lockout command (LLO) selects with local-with-lockout and remote-with-lockout pair versus remote and local without lockout. Lockout can only be canceled by the controller placing the remote enable line false, or the interface cable is disconnected.

3.2.4.2 POLLING COMMANDS

The IEEE standard provides two methods of determining the status of the devices in the system; namely serial poll and parallel poll. The parallel poll produces up to 8 bits of status from up to 8 different units simultaneously. A parallel poll is very fast but provides limited information. The serial poll provides 7 bits of status from one unit at a time.

Parallel Polling

The Model 6620 provides for software parallel poll configuration. This allows for assignment of a specific bit and its “true” state for response to a parallel poll. This bit is “true” when an error condition exists.

Configuring needs to be done only once or anytime the software desires to change the configuration. The commands related to parallel poll are as follows:

<u>IEEE-488 COMMAND</u>	<u>MNEMONIC</u>	<u>RESULT</u>
Configure	PPC	Places unit into a state where it expects parallel poll enable and disable commands to establish which bit should be set or selected in response to a parallel poll.
Unconfigure	PPU	Removes unit from PPC state (UNL does the same thing but also unlistens device).
Enable	PPE	When unit is in PPC state, it indicates which bit and which polarity the device should respond. Hex codes 60-67 selects bits 0-7 respectively to be set to 0 for a true error response. Since logic 0 is HI on open collector lines, this provides a logical “OR” of all units designated to respond with given line. Hex codes 68-6F selects bits 0-7 respectively to be set to 1 for a true (error) response. This can provide logical NAND of all units designated to respond with a given line.
Disable	PPD	Clears any configuration previously entered. This is valid only when unit is in PPC state.

Service Request and Serial Polling

The model 6620 has complete serial poll capabilities. When a serial poll is conducted, a “BYTE” of data is sent. Bits 0-3 indicate the type of error.

The following chart indicates the error types:

<u>B7-B0</u>	<u>HEX</u>	<u>ERROR TYPE</u>
0000 0000	00	No error
0000 0001	01	Signal Channel under range (<.01V)
0000 0010	02	Signal Channel over range (>320V)
0000 0100	04	Reference Channel under range (<.01V)
00001000	08	Reference Channel over range (>320V)

3.2.4.3 UNILINE MESSAGES

<u>IEEE-488 COMMAND</u>	<u>MNEMONIC</u>	<u>RESULT</u>
End	END	Sent with last byte of data. A line of data may either be terminated by a line feed character or by this command.
Identify	IDY	This command, issued by the controller, causes a parallel response which was previously configured by the PPC, PPD, PPE and PPU commands.
Remote Enable	REN	When true, allows the Model 6620 to respond to remote messages. When this line goes false, the unit will go to local-with-lockout state, activating the front panel.
Interface clear	IFC	Un-addresses all units and clears all special states.

3.3 RS-232C INTERFACE

3.3.1 INTRODUCTION

The Electronic Industries Association (EIA) RS-232C Interface Standard describes an accepted method of communicating over a serial data link. The functional and mechanical interface is further outlined in RS-449. Implementation of these standards varies in practice. The RS-232C interface option for the Model 6620 was designed to be compatible with most computer equipment. The information provided describes a typical interface. The proper implementation for some computers may vary.

3.3.2 THE CABLE

RS-232C communication can be achieved with a four-wire cable shown in Figure 3.3, on page 3-7. This method does not provide a hardware handshake. It does allow the user to implement the XON/XOFF protocol.

If a hardware handshake is required, a six-wire cable is necessary as shown in Figure 3.4, on page 3-8. The Model 6620 will turn off its DTR line when the input buffer is full. This hardware handshake is

particularly useful when the host computer employs buffered output and can delay transmission when DSR goes false. Hardware handshake can also be used by the host computer when its' input buffer is full to delay data being transmitted from the Model 6620.

The XON/XOFF protocol may also be used over the six-wire cable.

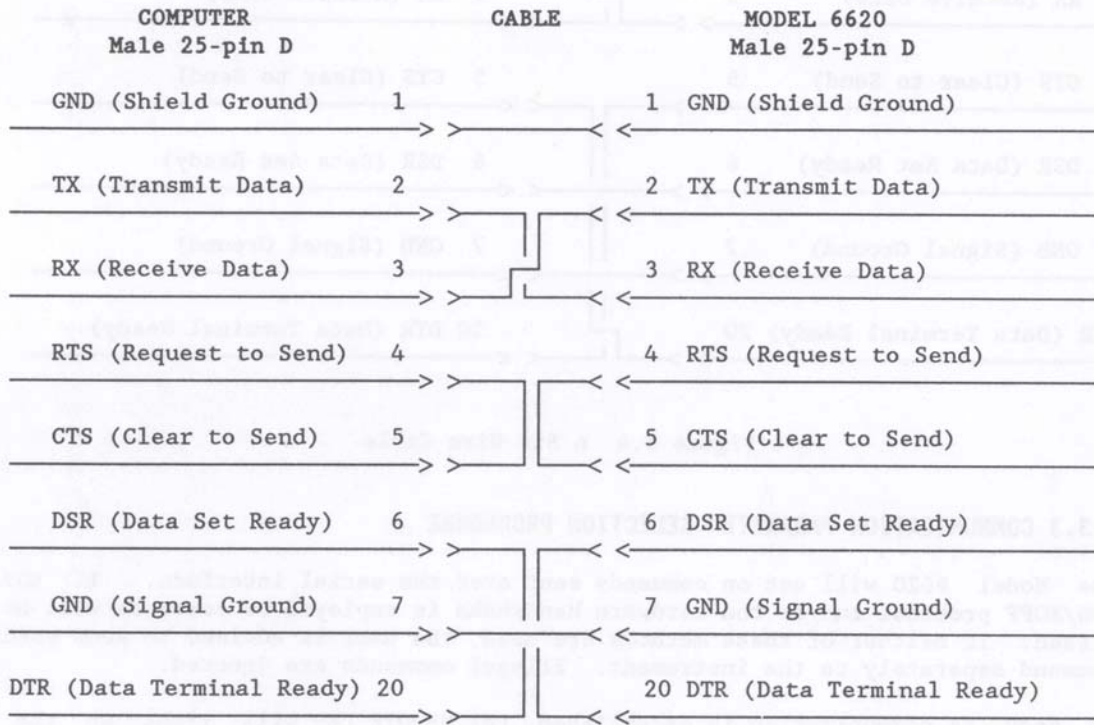

Figure 3.3 A Four-Wire Cable

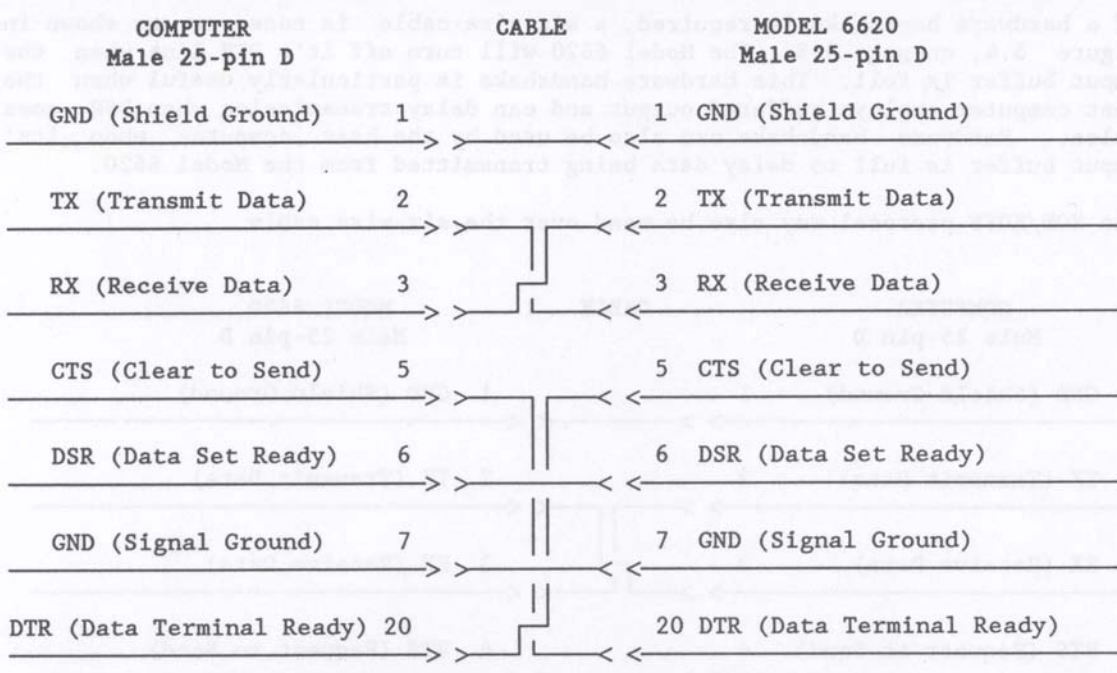

Figure 3.4 A Six Wire Cable

3.3.3 COMMUNICATION PARAMETER SELECTION PROCEDURE

The Model 6620 will act on commands sent over the serial interface. If the XON/XOFF protocol and/or the hardware handshake is employed no commands will be missed. If neither of these methods are used, the user is advised to send each command separately to the instrument. Illegal commands are ignored.

As soon as communication is established, the REMOTE LED will light on the front panel. When the REMOTE LED is on, the phasemeter will no longer respond to the front panel. Front panel operating can be resumed by pressing the [LOCAL] key.

When the unit is in [LOCAL] mode, the [LOCAL] key is used to select a number of communication parameters. When the [LOCAL] key is first pressed momentarily, the baud rate (Menu 1) will appear on the DISPLAY. Pressing the [METER RANGE] and [REL PHASE] keys will increase or decrease respectively the seven available baud rates which vary from 300 to 9600 bits/second (see Figure 3.5).

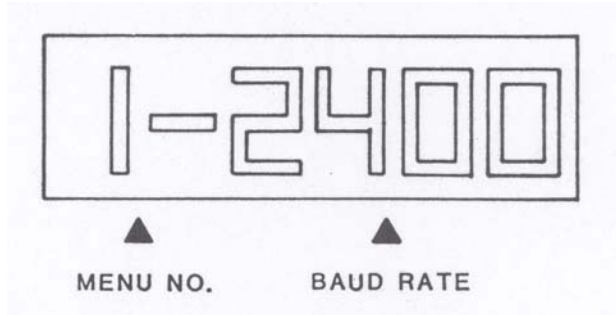

Figure 3.5 Baud Rate

Pressing the [LOCAL] key again momentarily, will display the line termination (Menu 2). The desired termination, shown in Figure 3.6, is obtained by pressing the [METER RANGE] and [REL PHASE] keys. While the Model 6620 ignores line termination as input, some computers may not.

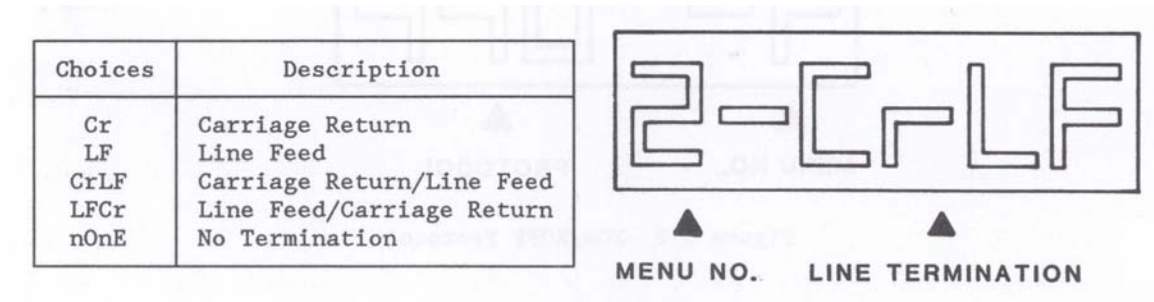

Figure 3.6 Line Termination

Three parameters are chosen in Menu 3. The first character in the display represents the number of DATA BITS. The second character selects (E)ven, (O)dd or (N)o PARITY. The last character selects the number of STOP BITS (see Figure 3.7).

Choices	Data Bits	Parity	Stop Bits
8n2	8	none	2
8n1	8	none	1
7n2	7	none	2
7O2	7	odd	2
7E2	7	even	2
7n1	7	none	1
7O1	7	odd	1
7E1	7	even	1

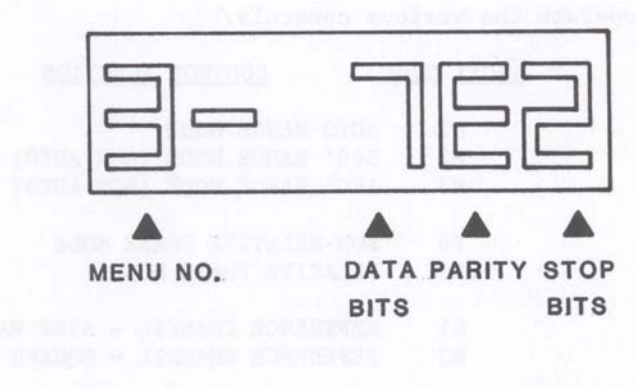

Figure 3.7 Parameter

Menu 4 determines if the XON/XOFF protocol will be used. Pressing the [LOCAL] key when Menu 4 is displayed, returns the instrument to normal operation (see Figure 3.8)

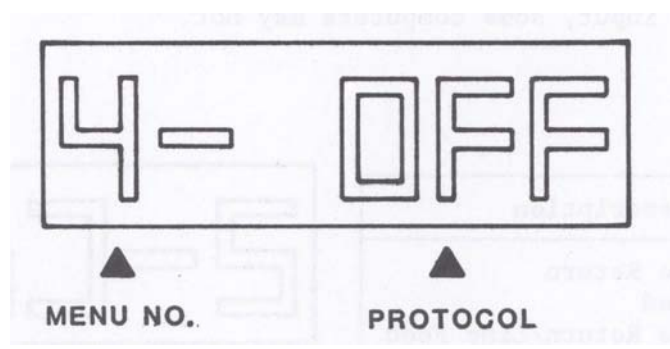

Figure 3.8 XON/XOFF Protocol

The communication parameters are stored in non-volatile ram and will be selected each time the phasemeter is turned on.

3.3.4 RS-232C DATA TRANSFER

RECEIVE COMMANDS

The Model 6620 can receive commands at any time. The command is executed immediately upon receipt. This means that no line termination character(s) is needed, however, one may be sent if desired.

The following chart indicates the ASCII characters that must be received to operate the various controls.

<u>ASCII CODE</u>	<u>CONTROL FUNCTION</u>
M1	Auto Range Mode
M2	360° Range Mode (non-auto)
M3	180° Range Mode (non-auto)
P0	Non-Relative Phase Mode
P1	Relative Phase Mode
R1	Reference Channel = Sinewave
R2	Reference Channel = Squarewave
S1	Signal Channel = Sinewave
S2	Signal Channel = Squarewave
T0	No Line Termination
T1	Line Termination = <CR>
T2	Line Termination = <LF>
T3	Line Termination = <CR><LF>
T4	Line Termination = <LF><CR>
C1	Manual 0° Calibration
C2	Manual 180° Calibration
C3	Manual 360° Calibration
C4	Auto Calibration
Q1	Service Request On
Q2	Query Status

SEND DATA

The Model 6620 when sending data, sends a “space” first, followed by the data and terminated with the selected line-termination-character(s). The data to be sent after a “Q1” (Query Phase Angle Command) is the front panel display. After the receipt of the “Q2” (Query Status Command) the Status is sent.

The following chart indicates the format of the STATUS data sent by the Model 6620. Position is indicated from left to right, thus, “1-Signal Channel Mode” references the MSD of the Status word.

- 1 SIGNAL CHANNEL MODE
 1 = sinewave
 2 = squarewave
- 2 SIGNAL CHANNEL ERROR INDICATORS
 0 = signal channel within range (No Error)
 1 = signal channel under range
 2 = signal channel overload error
- 3 REFERENCE CHANNEL MODE
 1 = sine wave
 2 = square wave

- 4 **REFERENCE CHANNEL ERROR INDICATORS**
 - 0 = reference channel within range (No Error)
 - 1 = reference channel under range
 - 2 = reference channel overload error

- 5 **PHASEMETER RANGE INDICATORS**
 - 1 = manual range mode/360° range
 - 2 = manual range mode/180° range
 - 3 = auto range mode/360° range
 - 4 = auto range mode/180° range

- 6 **RELATIVE PHASE MODE INDICATOR**
 - 0 = absolute phase mode
 - 1 = relative phase mode

- 7 **CALIBRATION INDICATORS**
 - 0 = no calibration LED's lit
 - 1 = 0° calibration LED's lit
 - 2 = 180° calibration LED lit
 - 3 = 360° calibration LED lit

SECTION 4

INCOMING ACCEPTANCE

4.1 INTRODUCTION

The following procedure should be used to verify that the Model 6620 phasemeter is operating within specifications. These tests may be used for incoming acceptance and periodic performance checks. The procedure should be followed in sequence, with the covers in place, and the phasemeter operating for ½ hour to reach thermal equilibrium.

Before testing, follow the operation procedure in Section 2 of this manual. If not operating within specifications, refer to Section 5, Calibration, before attempting any detailed maintenance.

NOTE

As an alternate to the following procedure, a Primary Phase Angle Standard, such as the Daytronics Model 311/RT-1/717S may be used for accuracy measurements between 30Hz and 10kHz. Another alternative is the use of Computing Counter System, such as the HP Model 5360A when used with a suitable phase shifting circuit.

4.2 REQUIRED TEST EQUIPMENT

The test equipment below is required to perform the following tests.

- a. Low Distortion Oscillator: frequency range from 1Hz to 100kHz with quadrature output. Distortion <0.01% from 10Hz to 20kHz rising to 0.1% at 100kHz. Krohn-Hite Model 4024A or equivalent.
- b. RC Oscillator: frequency range from 10ZHz to 10MHz with balanced output. Two Krohn-Hite Model 4300B (operating in synchronism as shown in Figure 4.1) or HP Model 654A.
- c. Variable Phase Generator: adjustable phase angle from 0° to 360°. HP Model 203A or equivalent.
- d. DVM: Fluke Model 8012A or equivalent.
- e. Matched set of coaxial cables (BNC) of the same type and length.

4.3 PROCEDURE

4.3.1 Display Calibration

After the Model 6620 has been operating in [LOCAL] mode (see Section 3.8) for a minimum of ½ hour, with covers in place, proceed with calibration.

1. Pressing the [MAN] key in the CALIBRATE section momentarily, will light the 0° LED indicator intermittently. Adjust the screwdriver control below the LED so DISPLAY indicates 0.00°.
2. Pressing the [MAN] key momentarily again, will light the 180° LED intermittently. Adjust the screwdriver control below the 180° LED so DISPLAY indicates 180.00°.
3. Pressing the [MAN] key momentarily again, will light the 360° LED intermittently. Adjust the screwdriver control below the 360° LED so DISPLAY indicates 360.00°.

When the key is momentarily pressed again, the DISPLAY will return to normal operation.

4. Pressing the [AUTO] key in the CALIBRRATE section, selects the AUTO METER CORRECT (AMC) mode. The unit will cycle through and automatically calibrate the display at 0°, 180° and 360° and respective LEDs will cycle off and on. This mode will not calibrate the analog output of the unit, only the DISPLAY.

4.3.2 Low Frequency Sinewave Check

Connect the output of the low-distortion oscillator, with matched cables (same type and length), to both the REFERENCE and SIGNAL inputs. Set both waveform selectors of the phasemeter to the sinewave mode, the oscillator frequency to 100Hz and its amplitude to 0.5Vrms. Set the phasemeter to the $\pm 180^\circ$ meter range. The DISPLAY should indicate $0.00^\circ \pm 0.05^\circ$. Set the phasemeter to the 0-360° meter range. The DISPLAY should indicate $0.00^\circ \pm 0.05^\circ$. Press the key in the CALIBRATE section until the 360° LED lights intermittently. Wait for a few seconds for the DISPLAY to stabilize and then press the key momentarily to return the phasemeter to normal operating. The DISPLAY should indicate $360.00^\circ \pm 0.5^\circ$. Repeat this procedure at 10Hz, 1kHz, 10kHz and 50kHz, and oscillator amplitudes of 1.5V and 5Vrms.

4.3.3 High Frequency Sinewave Check

Connect the output of the RC oscillator, with matched cables to both inputs. Set the oscillator frequency to 100kHz and its amplitude to 0.5Vrms. Set the phasemeter to the $\pm 180^\circ$ meter range. The DISPLAY should indicate $0.00^\circ \pm 0.35^\circ$. Set the phasemeter to the 0-360° meter range. The DISPLAY should indicate $0.00^\circ \pm 0.35^\circ$. Press the key in the CALIBRATE section until the 360° LED lights intermittently. Wait a few seconds for the DISPLAY to stabilize and then press the key momentarily to return the phasemeter to normal operation. The display should indicate $360.00^\circ \pm .35^\circ$. The same specifications apply when the above procedure is repeated at amplitude of 1.5Vrms. Repeat the above procedure at 500kHz, and 1MHz. The DISPLAY tolerance should be $\pm 2^\circ$ at 500kHz and $\pm 4^\circ$ at 1MHz.

4.3.4 Quadrature Low Frequency Sinewave Check

Connect the output of the low distortion oscillator to the REFERENCE input and the quadrature output to the SIGNAL input. Set the meter range of the phasemeter to 0-360°, the oscillator to 100Hz and the amplitude of both outputs to 0.5Vrms. Record the phase reading.

Reverse the inputs and record the phase readings. The sum of both readings should be $360^\circ \pm 0.10^\circ$. The tolerance of this sum is twice the specified accuracy of 0.05° . Repeat this procedure at 1kHz, 10kHz and 50kHz.

Set the meter range of the phasemeter to $\pm 180^\circ$ and repeat the above procedure. The sum of both readings should be $\pm 0.05^\circ$.

4.3.5 Balanced High Frequency Sinewave Check

Connect the output of one RC oscillator to the REFERENCE input of the phasemeter and the output of another RC oscillator to the SIGNAL input. Balanced output, is obtained by synchronizing the two oscillators. Set the meter range of the phasemeter to 0-360, both oscillators to 100kHz and their amplitudes to 0.5Vrms. Fine tune one oscillator, by monitoring both oscillators on a suitable scope, to obtain balanced output. Record the phase reading.

Reverse the two inputs and record the phase reading. The sum of both readings should be $360.00^\circ \pm 0.7^\circ$. The tolerance of this sum is twice the specified accuracy of 0.35° . Repeat this procedure at 500kHz and 1MHz. Tolerance of the total reading is $\pm 3.5^\circ$ at 500kHz and $\pm 7^\circ$ at 1MHz.

4.3.6 Balanced Low Frequency Squarewave Check

Connect two RC oscillators as in 4.3.5. Set both oscillators to the square wave mode, frequency to 100Hz and amplitude to 1.5Vrms. Fine tune one oscillator, by monitoring both oscillators on a suitable scope, to obtain balanced output. Record the phase reading.

Reverse the two inputs and record the phase reading. The sum of both readings should be $360^\circ \pm 0.2^\circ$. The tolerance of this sum is twice the specified accuracy of 0.1° . Repeat this procedure at 10Hz, 1kHz, 10kHz and 50kHz. Tolerance for the sum of these frequencies is also $360^\circ \pm 0.2^\circ$.

4.3.7 Balanced High Frequency Squarewave Check

Connect two RC oscillators as in 4.3.5. Set both oscillators to the square wave mode, frequency to 100Hz and amplitude to 1.5Vrms. Fine tune one oscillator, by monitoring both oscillators on a suitable scope, to obtain balanced output. Record the phase reading.

Reverse the two inputs and record the phase readings. The sum of both readings should be $360^\circ \pm 1.4^\circ$. The tolerance of this sum is twice the specified accuracy of 0.7° . Repeat this procedure at 500kHz and 1MHz. Tolerance for the total reading is $\pm 7^\circ$ at 500kHz and $\pm 14^\circ$ at 1MHz.

4.3.8 Analog Output Check

Connect the sinewave outputs of a variable phase generator, or two Krohn-Hite Model 4300B oscillators operating in synchronism, to the phasemeter inputs. Set both oscillators or variable phase generator to 1kHz at 1Vrms. Connect the DVM in the DC mode to the rear panel analog output connector. Set the variable phase generator for 180° or adjust one of the Model 4300B oscillators to obtain 180° phase shift, as shown on the DISPLAY of the phasemeter. The DVM should indicate 1.8Vdc. When the oscillators or generator are set to 170° , as shown on the phasemeter, the analog output should drop to 1.7Vdc or 10mV/degree. This will apply to any phase angle between 0° and 360° .

4.3.9 Relative Phase Check

If the phasemeter is set to the RELATIVE PHASE mode, the DISPLAY should switch from its initial phase to 000.00° and permit phase deviation measurements relative to its initial phase. When returned to the normal mode, the DISPLAY should indicate the original phase.

End of procedure.