

Digital Phosphor Oscilloscopes

DPO3000 Series Data Sheet

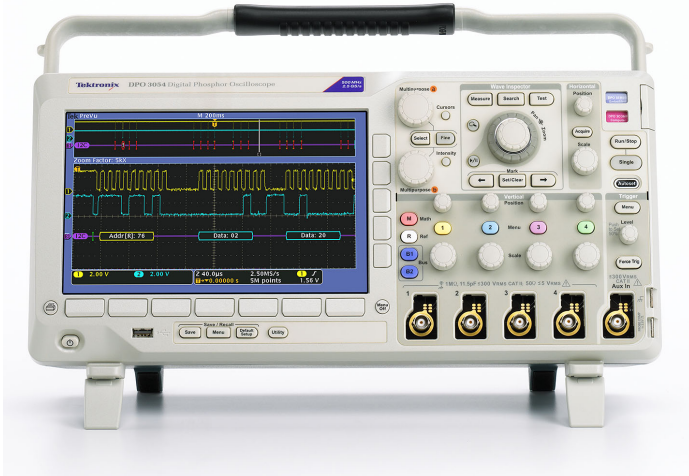

Features & Benefits

Key Performance Specifications

- 500, 300, 100 MHz Bandwidth Models
- 2 and 4 Channel Models
- 2.5 GS/s Sample Rate on All Channels
- 5 Megasample Record Length on All Channels
- 50,000 wfm/s Maximum Waveform Capture Rate
- Suite of Advanced Triggers

Ease of Use Features

- Wave Inspector® Controls Provide Unprecedented Efficiency in Waveform Analysis
- 9 in. (229 mm) WVGA Widescreen Color Display
- USB 2.0 Port on Front Panel for Quick and Easy Data Storage
- USB Plug-and-Play PC Connectivity
- TekVPI® Probe Interface Supports Active, Differential and Current Probes for Automatic Scaling and Units
- Small Footprint and Lightweight – Only 5.4 in. (137 mm) deep and 9 lb. (4 kg)

Serial Bus Trigger and Decode

- Serial Triggering, Decode, and Analysis Options for I²C, SPI, RS-232/422/485/UART, I²S/LJ/RJ/TDM, CAN, and LIN

Additional Application Support

- Power Analysis Option
- HDTV and Custom Video Analysis Option

Applications

- Embedded Design and Debug
- Investigation of Transient Phenomena
- Power Measurements
- Video Design and Debug
- Automotive Electronics Design and Debug

DPO3000 Series Digital Phosphor Oscilloscopes

The Power to Solve Problems Quickly

The DPO3000 Series digital phosphor oscilloscopes (DPO) deliver the performance you need to visualize even your most demanding signals. Bandwidths range from 100 MHz to 500 MHz, and with all models offering a minimum of 5x oversampling on all channels and sin(x)/x interpolation standard, you can be confident that even the fastest transient events will be captured and displayed accurately. The standard 5 M record length on all channels enables you to capture long windows of signal activity while maintaining fine timing resolution. The 50,000 wfm/s waveform capture rate maximizes the probability of capturing elusive glitches and other infrequent events.

The DPO3000 Series offers a variety of analytical solutions including cursors, 29 automatic measurements, statistics, and waveform math. Despite a tiny footprint (only 5.4 in. deep) and light weight (9 lb.), the DPO3000 Series offers exceptional performance, a large 9 in. WVGA widescreen display and knob-per-channel vertical controls.

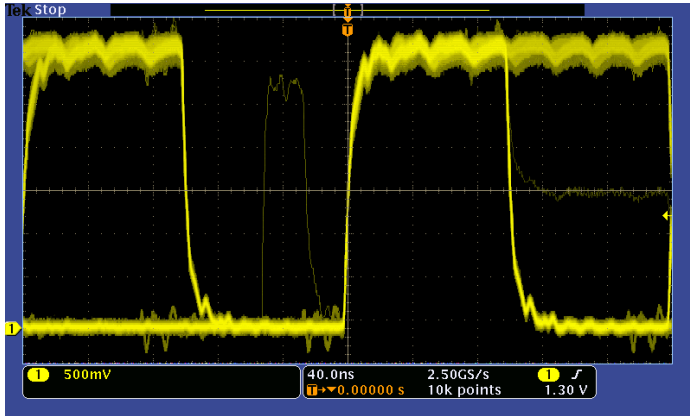

Fast waveform capture rate maximizes the probability of capturing elusive glitches and other infrequent events.

Perform Serial Debug for Common Standards

Serial Triggering and Analysis

One of the most common applications requiring long record length is serial data analysis in embedded system design. Embedded systems are literally everywhere. They can contain many different types of devices including microprocessors, microcontrollers, DSPs, RAM, EPROMs, FPGAs, A/Ds, D/As, and I/O. These various devices have traditionally communicated with each other and the outside world using wide parallel buses. Today, however, more and more embedded systems are replacing these wide parallel buses with serial buses due to less board space required, fewer pins, lower power, embedded clocks, differential signaling for better noise immunity, and most importantly, lower cost. While serial buses have a large number of benefits, they also present significant challenges that their predecessors (parallel buses) did not. Debugging bus and system problems can be more difficult, because it is harder to isolate events of interest, and it is more difficult to interpret what is displayed on the oscilloscope screen. The DPO3000 Series addresses these problems.

Bus Display – Provides a higher level, combined view of the individual signals (clock, data, chip enable etc.) that make up your bus, making it easy to identify where packets begin and end and identifying subpacket components such as address, data, identifier, CRC, etc.

Serial Triggering – Trigger on packet content such as start of packet, specific addresses, specific data content, unique identifiers, etc., on the popular serial interfaces I²C, SPI, RS-232/422/485/UART, I²S/LJ/RJ/TDM, CAN, and LIN.

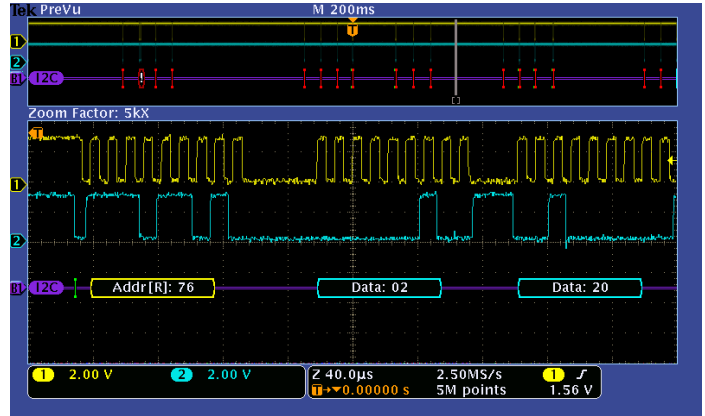

Triggering on a specific data packet going across an I²C bus. The yellow waveform is clock and the blue waveform is data. A Bus waveform provides decoded packet content including Start, Address, Read/Write, Data, and Stop.

Time	Identifier	DLC	Data	CRC	Missing Ack
-128.2ms	1597EEB2	8	88FD BF1A 1D0C 28B347E		
-68.82ms	1597EED1	8	88FD BF2A 1D0C 28B34863		
-36.38ms	734	0	Remote Frame	1C27	
-24.005s	734	3	0000 FF	2087	
34.95ms	76D	2	000A	ACB	
92.43ms	1597EEA3	6	00FD 000A 1D0C	5F84	
98.51ms	Overload Frame				
153.1ms	1597EEB2	8	0272 DFAE 4FFF F1022180		
213.4ms	1597EED1	8	0D0A 0BDF 37D3 0F012F6E		
273.4ms	1597EEA3	8	0000 00DE 55CB F45L10BD		
321.8ms	1597EEB2	3	00DF EF	930	
361.0ms	1597EEA3	0	Remote Frame	A4B	
459.7ms	734	8	FF81 55DF EFCF 45AL83C		
511.9ms	76D	8	FF00 00FF FF00 00E1706A		
565.0ms	76D	8	2DF6 DAFF FF00 00E1706A		
625.0ms	1597EEB2	8	37D3 55FF FF00 00E1216E		

Packet decode table showing decoded Identifier, DLC, Data, and CRC for every CAN packet in a long acquisition.

Bus Decoding – Tired of having to visually inspect the waveform to count clocks, determine if each bit is a 1 or a 0, combine bits into bytes and determine the hex value? Let the oscilloscope do it for you! The oscilloscope can decode each packet on the bus and display the value in hex, binary, decimal, signed decimal, or ASCII (depending on the standard) in the bus waveform.

Packet Decode Table – In addition to seeing decoded packet data on the bus waveform itself, you can view all captured packets in a tabular view much like you would see on a logic analyzer. Packets are time stamped and listed consecutively with columns for each component (Address, Data, etc.).

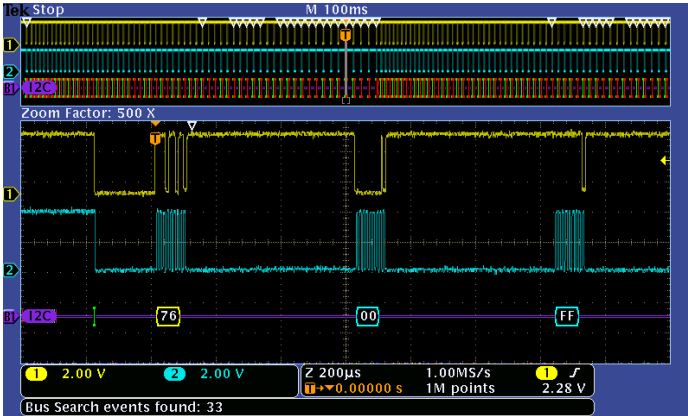

I²C decode showing results from a search for Address value 76. The white triangles indicate each instance of the Address value 76 in the record.

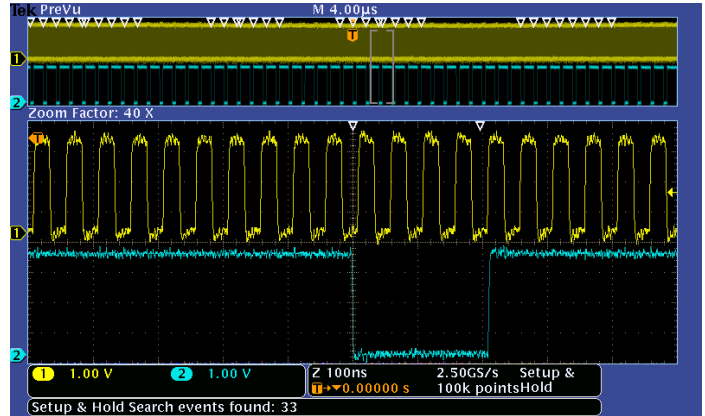

Setup and Hold search results showing each violation of a setup and hold condition.



Wave Inspector Controls provide unprecedented efficiency in viewing, navigating, and analyzing waveform data.

Search – Serial triggering is very useful for isolating the event of interest, but once you've captured it and need to analyze the surrounding data, what do you do? In the past, users had to manually scroll through the waveform counting and converting bits and looking for what caused the event. With the DPO3000 Series, you can have the oscilloscope search through the acquired data for user-defined criteria including serial packet content. Each occurrence is highlighted by a search mark. Rapid navigation between marks is as simple as pressing the **Previous** (←) and **Next** (→) buttons on the front panel.

Designed to Make Your Work Easier

Wave Inspector® Navigation

Imagine trying to efficiently use the Internet if search engines such as Google and Yahoo didn't exist, web browser features such as Favorites and Links didn't exist, or Internet Service Providers like AOL or MSN weren't around. Now you know how most modern oscilloscope users feel when trying to actually use the long record length in their digital oscilloscope. Record length, one of the key specifications of an oscilloscope, is the number of samples it can digitize and store in a single acquisition. The longer the record length, the longer the time window you can capture with high resolution (high sample rate). The first digital oscilloscopes could capture and store only 500 points which made it very difficult to acquire all relevant information around the event being investigated. Over the years, oscilloscope manufacturers have provided longer and longer record lengths to meet market demands for long capture windows with high resolution to the point that most mid-range oscilloscopes either come standard with, or can be optionally upgraded to, multimillion-point record lengths. These million-point record lengths often represent thousands of screens worth of signal activity. While standard record lengths have increased greatly over the years and can now satisfy the vast majority of applications in the marketplace, tools for effectively and efficiently viewing, navigating, and analyzing long record length acquisitions have been sorely neglected until now.

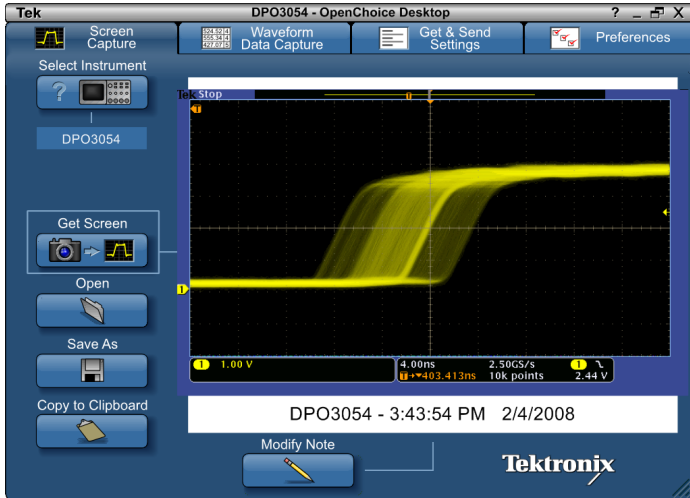

OpenChoice® Desktop – Standard software seamlessly connects the oscilloscope to a PC.

The DPO3000 Series addresses the need for working with long record lengths with the following innovative Wave Inspector controls:

Zoom/Pan – A dedicated, two-tier front-panel knob set provides intuitive control of both zooming and panning through acquired records. The inner knob adjusts the zoom factor (or zoom scale); turning it clockwise activates zoom and goes to progressively higher zoom factors, while turning it counterclockwise results in lower zoom factors and eventually turning zoom off. The outer knob pans the zoom box across the waveform to quickly get to the portion of the waveform you are interested in. The outer knob also utilizes force-feedback to determine how fast to pan on the waveform. The farther you turn the outer knob, the faster the zoom box moves. Pan direction is changed by simply turning the knob the other way. No longer do you need to navigate through multiple menus to adjust your zoom view.

Play/Pause – A dedicated **Play/Pause** button on the front panel scrolls the waveform across the display automatically while you look for anomalies or an event of interest. Playback speed and direction are controlled using the intuitive pan knob. Once again, turning the knob further makes the waveform scroll faster and changing direction is as simple as turning the knob the other way.

User Marks – See something interesting on your waveform? Press the **Set Mark** button on the front panel to leave one or more “bookmarks” on the waveform. Navigating between marks is as simple as pressing the **Previous** (←) and **Next** (→) buttons on the front panel.

Search Marks – Don't want to take the time to inspect the entire acquisition to find the event you're looking for? The DPO3000 Series features robust waveform search that allows you to search through your long acquisition based on user-defined criteria. All occurrences of the event are highlighted with search marks and are easily navigated to, using the front panel's **Previous** (←) and **Next** (→) buttons. Search types include edge, pulse width, runt, logic, setup and hold, rise/fall time and I²C, SPI, RS-232/422/485/UART, I²S/LJ/RJ/TDM, CAN, and LIN packet content.

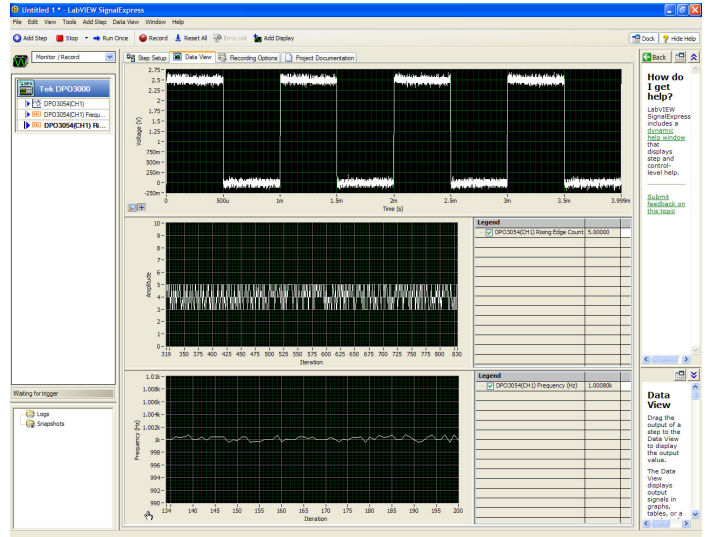

NI LabVIEW SignalExpress Tektronix Edition – Fully interactive measurement acquisition and analysis software developed jointly with NI, and optimized for the DPO Series.

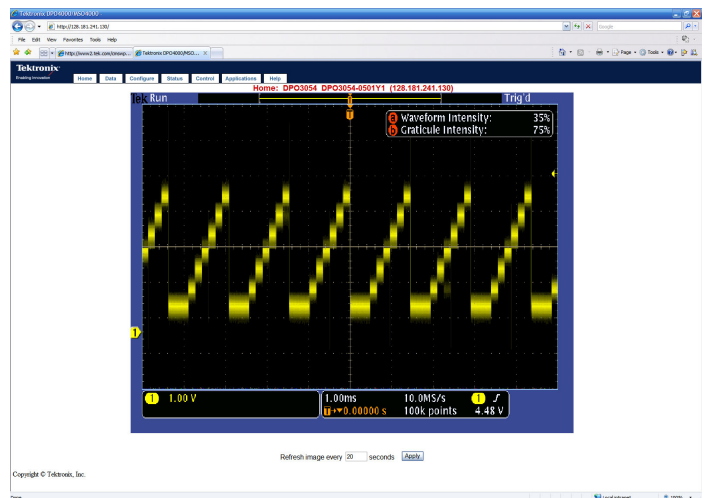

e*Scope enables control of your network connected oscilloscope from any network connected PC through a traditional browser interface.

PC Connectivity and USB Mass Storage

The DPO3000 Series delivers an unprecedented new level of USB plug-and-play operation and PC connectivity. A USB port on the front panel enables easy transfer of screenshots, instrument settings, and waveform data in the palm of your hand. Also, a second USB host port is on the rear of the instrument along with a USB device port which can operate as a USBTMC device port for controlling the oscilloscope remotely from a PC. An integrated 10/100 Ethernet port enables easy connection to networks. Acquiring data and measurements from the instrument is as simple as connecting a USB cable from the oscilloscope to the PC. Provided applications include NI LabVIEW SignalExpress™ Tektronix Edition, OpenChoice® Desktop and Microsoft Excel and Word toolbars enabling fast and easy direct communication with your Windows PC.



TekVPI probe interface

TekVPI® Probing

The TekVPI probe interface sets the standard for ease of use in probing. TekVPI probes feature status indicators and controls, as well as a probe menu button right on the comp box itself. This button brings up a probe menu on the oscilloscope display with all relevant settings and controls for the probe. The TekVPI interface utilizes a new probe power management architecture enabling direct attachment of current probes. Finally, TekVPI probes can be controlled remotely using USB, GPIB, or Ethernet, enabling more versatile solutions in ATE environments.

Additional Application Support

Power Analysis

Ever increasing consumer demand for longer battery life devices and for green solutions that consume less power, require power-supply designers to characterize and minimize switching losses to improve efficiency. In addition, the supply's power levels, output purity, and harmonic feedback into the power line must be characterized to comply with national and regional power quality standards. Historically, making these and many other power measurements on an oscilloscope has been a long, manual, and tedious process. The DPO3PWR Power Analysis application module greatly simplifies these tasks, enabling quick and accurate analysis of power quality, switching loss, harmonics, safe operating area (SOA), modulation, ripple, and slew rate (dI/dt, dV/dt). Completely integrated into the

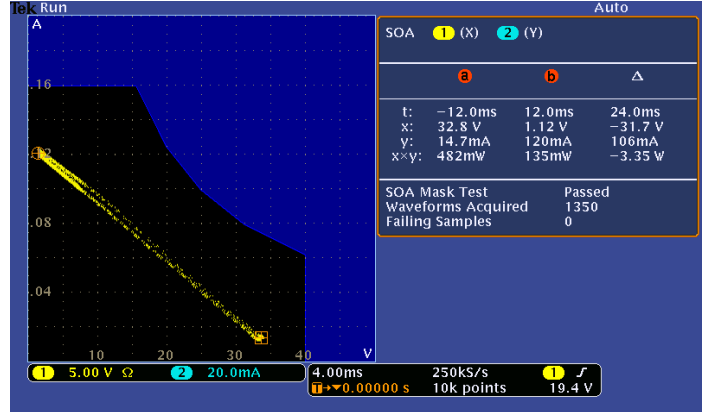

Safe operating area measurement. Automated power measurements enable quick and accurate analysis of common power parameters.

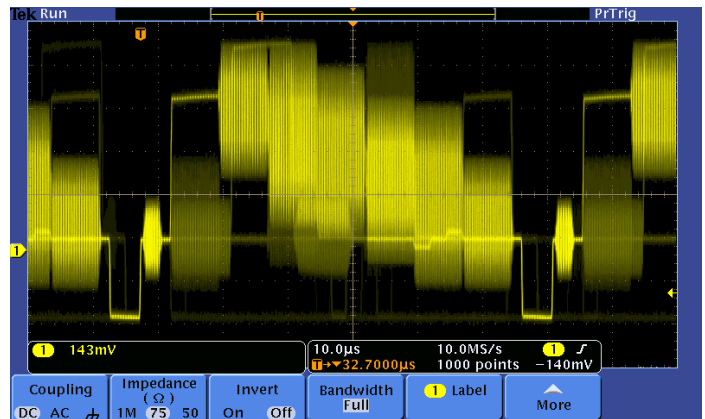

Viewing an NTSC video signal. Notice the intensity-graded view provided by the DPO's ability to represent time, amplitude, and distribution of amplitude over time.

oscilloscope, DPO3PWR provides automated power measurements with a touch of a button, no external PC or complex software setup is required.

Video Design and Development

Many video engineers have remained loyal to analog oscilloscopes, believing the intensity gradations on an analog display are the only way to see certain video waveform details. The DPO3000 Series fast waveform capture rate, coupled with its intensity-graded view of the signal, provides the same information-rich display as an analog oscilloscope, but with much more detail and all the benefits of digital scopes. With up to 500 MHz bandwidth, four inputs, and a built-in 75 Ω input termination, the DPO3000 Series provides ample performance for analog and digital video use.

Finally, the DPO3000 Series video functionality is further extended with the optional DPO3VID video application module. DPO3VID provides the industry's most complete suite of HDTV and custom (nonstandard) video triggers.

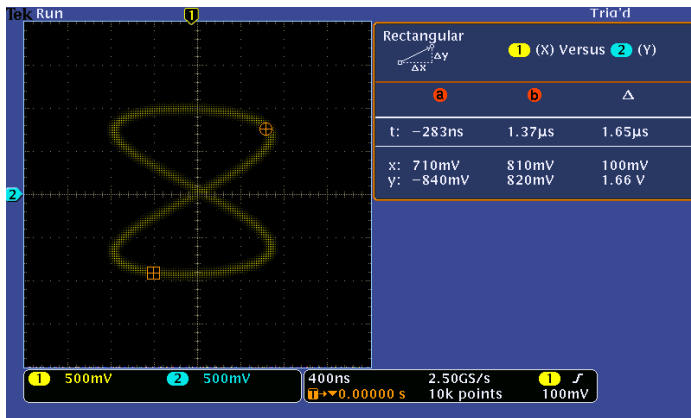

XY display showing a 20 MHz clock and a 10 MHz clock.

Digital Design and Debug

Today's digital designs often require careful layout of circuitry to guarantee consistent time alignment between clocks on circuit boards. Small differences in delays caused by routing issues or inconsistent propagation time across a circuit board can cause numerous issues with the operation of digital functional blocks. The DPO3000 Series can assist in finding those small phase shifts that occur between clocks as they migrate across a design. XY display of two clocks can give a quick visual indication of a phase difference between them. Frequency differences can also quickly be seen. This can be very helpful when determining how effective clock multiplier or divider networks are working.

The interoperability of the DPO3000 Series oscilloscope with the Tektronix TLA5000 Series logic analyzer made possible by Tektronix' Integrated View (iView™) feature enables digital designers to solve signal integrity challenges and effectively debug and verify their systems more quickly



Tektronix' Integrated View feature (iView™) fully integrates the performance and measurement accuracy of a Tektronix oscilloscope with the multichannel and powerful triggering capabilities of a Tektronix logic analyzer in one display, allowing designers to quickly verify and debug their designs.

and easily. The iView feature fully integrates the industry-leading performance and measurement accuracy of a Tektronix oscilloscope with the multichannel and powerful triggering capabilities of a Tektronix logic analyzer. This integration allows designers to view time-correlated digital and analog data in the same display window, and isolate analog characteristics of digital signals that are causing failures in their systems. No user calibration is required. And, once set up, the iView feature is completely automated. The result – an integrated tool set for digital design and troubleshooting.

Characteristics

Vertical System

Characteristic	DPO3012	DPO3014	DPO3032	DPO3034	DPO3052	DPO3054
Input Channels	2	4	2	4	2	4
Analog Bandwidth (-3dB)	100 MHz	100 MHz	300 MHz	300 MHz	500 MHz	500 MHz
Calculated Rise Time 5 mV/div (typical)	3.5 ns	3.5 ns	1.17 ns	1.17 ns	700 ps	700 ps
Hardware Bandwidth Limits	20 MHz or 150 MHz					
Input Coupling	AC, DC, GND					
Input Impedance	1 M Ω \pm 1%, 75 Ω \pm 1%, 50 Ω \pm 1%					
Input Sensitivity Range, 1 M Ω	1 mV/div to 10 V/div					
Input Sensitivity Range, 75 Ω , 50 Ω	1 mV/div to 1 V/div					
Vertical Resolution	8 bits (11 bits with Hi Res)					
Max Input Voltage, 1 M Ω	300 V _{RMS} with peaks \leq \pm 450 V					
Max Input Voltage, 75 Ω , 50 Ω	5 V _{RMS} with peaks \leq \pm 20 V					
DC Gain Accuracy	\pm 1.5% with offset set to 0 V					
Offset Range	1 M Ω				50 Ω , 75 Ω	
1 mV/div to 99.5 mV/div	\pm 1 V				\pm 1 V	
100 mV/div to 995 mV/div	\pm 10 V				\pm 5 V	
1 V/div	\pm 100 V				\pm 5 V	
1.01 V/div to 10 V/div	\pm 100 V				NA	
Channel-to-Channel Isolation (Any Two Channels at Equal Vertical Scale)	\geq 100:1 at \leq 100 MHz and \geq 30:1 at $>$ 100 MHz up to the rated BW					

Horizontal System

Characteristic	All DPO3000 Models
Maximum Sample Rate (all channels)	2.5 GS/s
Maximum Record Length (all channels)	5 M points
Maximum Duration of Time Captured at Highest Sample Rate (all channels)	2 ms
Time base Range (S/div)	1 ns to 1000 s
Time base Delay Time Range	-10 divisions to 5000 s
Channel-to-Channel Deskew Range	\pm 100 ns
Timebase Accuracy	\pm 10 ppm over any \geq 1 ms interval

Trigger System

Characteristic	Description
Main Trigger Modes	Auto, Normal, and Single
Trigger Coupling	DC, AC, HF reject (attenuates >50 kHz), LF reject (attenuates <50 kHz), noise reject (reduces sensitivity)
Trigger Holdoff Range	20 ns to 8 s
Trigger Frequency Readout	6-digit hardware counter indicates how often triggerable events are occurring in the user's signal.
Sensitivity	
Internal DC Coupled	0.4 div DC to 50 MHz, increasing to 1 div at rated bandwidth
External (Auxiliary Input)	200 mV from DC to 50 MHz increasing to 500 mV at 250 MHz
Trigger Level Range	
Any Channel	±8 divisions from center of screen
External (auxiliary input)	±8 V
Acquisition Modes	
Sample	Acquire sampled values
Peak Detect	Captures narrow glitches at all real-time sampling rates
Averaging	From 2 to 512 waveforms included in average
Envelope	Min-max envelope reflecting Peak Detect data over multiple acquisitions
Hi Res	Real-time boxcar averaging reduces random noise and increases resolution
Roll	Scrolls waveforms right to left across the screen at sweep speeds slower than or equal to 40 ms/div
Trigger Modes	
Edge	Positive or negative slope on any channel or front-panel auxiliary input. Coupling includes DC, AC, HF reject, LF reject, and noise reject.
Pulse Width	Trigger on width of positive or negative pulse that are >, <, =, or ≠ a specified period of time.
Runt	Trigger on a pulse that crosses one threshold but fails to cross a second threshold before crossing the first again.
Logic	Trigger when any logical pattern of channels goes false or stays true for specified period of time. Any input can be used as a clock to look for the pattern on a clock edge. Pattern (AND, OR, NAND, NOR) specified for four input channels defined as High, Low, or Don't Care.
Setup and Hold	Trigger on violations of setup time and/or hold time between clock and data present on any two input channels.
Rise/Fall Time	Trigger on pulse edge rates that are faster or slower than specified. Slope may be positive, negative, or either.
Video	Trigger on all lines, odd, even, or all fields on NTSC, PAL, and SECAM video signals.
Extended Video (optional)	Trigger on 480p/60, 576p/50, 720p/30, 720p/50, 720p/60, 875i/60, 1080i/50, 1080i/60, 1080p/24, 1080p/24sF, 1080p/25, 1080p/30, 1080p/50, 1080p/60, and custom bilevel and trilevel sync video standards.
I ² C (optional)	Trigger on Start, Repeated Start, Stop, Missing ACK, Address (7 or 10 bit), Data, or Address and Data on I ² C buses up to 3.4 Mbps.
SPI (optional)	Trigger on SS, MOSI, MISO, or MOSI and MISO on SPI buses up to 10.0 Mbps.
CAN (optional)	Trigger on Start of Frame, Frame Type (data, remote, error, overload), Identifier (standard or extended), Data, Identifier and Data, End of Frame, Missing ACK, or Bit Stuffing Error on CAN signals up to 1 Mbps. Data can be further specified to trigger on ≤, <, =, >, ≥, or ≠ a specific data value. User-adjustable sample point is set to 50% by default.
LIN (optional)	Trigger on Sync, Identifier, Data, Id and Data, Wakeup Frame, Sleep Frame, Error up to 100 kbps.
I ² S/LJ/RJ/TDM (optional)	Trigger on Word Select, Frame Sync, or Data. Data can be further specified to trigger on ≤, <, =, >, ≥, ≠ a specific data value, or inside or outside of a range.*1
RS-232/422/485/UART (optional)	Trigger on Tx Start Bit, Rx Start Bit, Tx End of Packet, Rx End of Packet, Tx Data, Rx Data, Tx Parity Error, and Rx Parity Error.
Trigger Delay by Time	4 ns to 8 s
Trigger Delay by Events	1 to 9,999,999 events

*1 Not available on 2-channel models.

Waveform Measurements

Characteristic	Description
Cursors	Waveform and Screen
Automatic Measurements	29, of which up to four can be displayed on screen at any one time. Measurements include: Period, Frequency, Delay, Rise Time, Fall Time, Positive Duty Cycle, Negative Duty Cycle, Positive Pulse Width, Negative Pulse Width, Burst Width, Phase, Positive Overshoot, Negative Overshoot, Peak to Peak, Amplitude, High, Low, Max, Min, Mean, Cycle Mean, RMS, Cycle RMS, Rising Edge Count, Falling Edge Count, Positive Pulse Count, Negative Pulse Count, Area, and Cycle Area.
Measurement Statistics	Mean, Min, Max, Standard Deviation
Reference Levels	User-definable reference levels for automatic measurements can be specified in either percent or units
Gating	Isolate the specific occurrence within an acquisition to take measurements on, using either the screen, or waveform cursors

Power Measurements (optional)

Characteristic	Description
Power Quality Measurements	V_{RMS} , $V_{Crest\ Factor}$, Frequency, I_{RMS} , $I_{Crest\ Factor}$, True Power, Apparent Power, Reactive Power, Power Factor, Phase Angle
Switching Loss Measurements	Power Loss: T_{on} , T_{off} , Conduction, Total Energy Loss: T_{on} , T_{off} , Conduction, Total
Harmonics	THD-F, THD-R, RMS measurements Graphical and table displays of harmonics Test to IEC61000-3-2 Class A and MIL-STD-1399
Ripple Measurements	V_{ripple} and I_{ripple}
Modulation Analysis	Graphical display of +Pulse Width, -Pulse Width, Period, Frequency, +Duty Cycle, and -Duty Cycle modulation types
Safe Operating Area	Graphical display and mask testing of switching device safe operating area measurements
dV/dt and dI/dt Measurements	Cursor measurements of slew rate

Waveform Math

Characteristic	Description
Arithmetic	Add, subtract, multiply, and divide waveforms
Math Functions	Integrate, Differentiate, FFT
FFT	Spectral magnitude. Set FFT Vertical Scale to Linear RMS or dBV RMS, and FFT Window to Rectangular, Hamming, Hanning, or Blackman-Harris.
Advanced Math	Define extensive algebraic expressions including waveforms, math functions, scalars, up to two user-adjustable variables and results of parametric measurements (both static and trend plots) e.g., $(Intg(Ch1 - Mean(Ch1)) \times 1.414 \times VAR1)$.

Software

Software	Description
NI LabVIEW SignalExpress™ Tektronix Edition	A fully interactive measurement software environment optimized for the DPO3000 Series, enables you to instantly acquire, generate, analyze, compare, import, and save measurement data and signals using an intuitive drag-and-drop user interface that does not require any programming. Standard DPO3000 Series support for acquiring, controlling, viewing, and exporting your live signal data. A 30-day trial period of the Full Version provides additional signal processing, advanced analysis, mixed signal, sweeping, limit testing and user-defined step capabilities. Order SIGEXPTX for permanent Full Version capability.
OpenChoice® Desktop	Enables fast and easy communication between a Windows PC and the DPO3000 Series, using USB or LAN. Transfer and save settings, waveforms, measurements, and screen images.
IVI Driver	Provides a standard instrument programming interface for common applications such as LabVIEW, LabWindows/CVI, Microsoft .NET, and MATLAB.

Display Characteristics

Characteristic	Description
Display Type	9 in. (228.6 mm) wide-format liquid-crystal TFT color display
Display Resolution	800 horizontal × 480 vertical pixels (WVGA)
Waveform Styles	Vectors, Dots, Variable Persistence, Infinite Persistence
Graticules	Full, Grid, Cross Hair, Frame, IRE, and mV
Format	YT and XY
Waveform Capture Rate	Up to 50,000 wfm/s

Input/Output Ports

Port	Description
USB 2.0 High-speed Host Port	Supports USB mass storage devices and printers. One port available on rear panel and one on front panel.
USB 2.0 High-speed Device Port	Rear-panel connector allows for control of oscilloscope through USBTMC or GPIB with a TEK-USB-488 or connection to a PictBridge® printer.
LAN Port	RJ-45 connector, supports 10/100Base-T
Video Out Port	DB-15 female connector, connect to show the oscilloscope display on an external monitor or projector
Auxiliary Input	Front-panel BNC connector. Input Impedance 1 MΩ. Max input 300 V_{RMS} Cat II with peaks ≤ ±450 V.
Probe Compensator Output	Front-panel pins Amplitude 2.5 V Frequency 1 kHz
Trigger Out	Rear-panel BNC connector, provides a positive polarity pulse when the oscilloscope triggers
Kensington Lock	Rear-panel security slot connects to standard Kensington lock

Power Source

Characteristic	Description
Power Source Voltage	85 to 265 V \pm 10%
Power Source Frequency	45 to 440 Hz (85 to 265 V)
Power Consumption	120 W maximum
Optional TekVPI® Power Supply	Output Voltage – 12 V Output Current – 5 A Power Consumption – 60 W

Physical Characteristics

Dimensions	mm	in.
Height	203.2	8
Width	416.6	16.4
Depth	137.2	5.4
Weight	kg	lb.
Net	4.17	9.2
Shipping	8.62	19
Rackmount Configuration	5U	
Cooling Clearance	2 in. (51 mm) required on left side and rear of instrument	

General Characteristics

Characteristic	Description
Environmental	
Temperature	
Operating	0 °C to +50 °C
Nonoperating	-40 °C to +71 °C
Humidity	
Operating	High: 30 °C to 50 °C, 5% to 45% Relative Humidity Low: 0 °C to 30 °C, 5% to 95% Relative Humidity
Nonoperating	High: 30 °C to 50 °C, 5% to 45% Relative Humidity Low: 0 °C to 30 °C, 5% to 95% Relative Humidity
Altitude	
Operating	3,000 meters (9,843 feet)
Nonoperating	12,000 meters (39,370 feet)
Random Vibration	
Operating	0.31 G _{RMS} from 5 to 500 Hz, 10 minutes each axis, 3 axes, 30 minutes total
Nonoperating	2.46 G _{RMS} from 5 to 500 Hz, 10 minutes each axis, 3 axes, 30 minutes total
Regulatory	
Electromagnetic Compatibility	89/336/EEC
Safety	UL61010-1, Second Edition; CAN/CSA C22.2 No. 1010.1 1992, EN61010-1:2001; IEC 61010-1:2001

Ordering Information**DPO3000 Series**

Product	Description
DPO3012	100 MHz, 2.5 GS/s, 5 M record length, 2-channel digital phosphor oscilloscope
DPO3014	100 MHz, 2.5 GS/s, 5 M record length, 4-channel digital phosphor oscilloscope
DPO3032	300 MHz, 2.5 GS/s, 5 M record length, 2-channel digital phosphor oscilloscope
DPO3034	300 MHz, 2.5 GS/s, 5 M record length, 4-channel digital phosphor oscilloscope
DPO3052	500 MHz, 2.5 GS/s, 5 M record length, 2-channel digital phosphor oscilloscope
DPO3054	500 MHz, 2.5 GS/s, 5 M record length, 4-channel digital phosphor oscilloscope

Included: All models include: One P6139A 500 MHz, 10x Passive Probe per Channel, Front Cover (200-5052-xx), User Manual, Documentation CD (063-4104-xx), OpenChoice® Desktop Software, NI LabVIEW SignalExpress™ Tektronix Edition LE Software, Calibration Certificate Documenting Traceability to National Metrology Institute(s) and ISO9001 Quality System Registration, Power Cord, Accessory Pouch (016-2008-xx), Three-year Warranty. Please specify power plug and manual language version when ordering.

Application Modules

Module	Description
DPO3AUDIO	Audio Serial Triggering and Analysis Module. Enables triggering on packet level information on I ² S, LJ, RJ, and TDM audio buses as well as analytical tools such as digital views of the signal, bus views, packet decoding, search tools, and packet decode tables with time stamp information.*1
DPO3AUTO	Automotive Serial Triggering and Analysis Module. Enables triggering on packet level information on CAN bus and LIN bus as well as analytical tools such as digital views of the signal, bus views, packet decoding, search tools, and packet decode tables with time stamp information.
DPO3EMBD	Embedded Serial Triggering and Analysis Module. Enables triggering on packet level information on I ² C and SPI buses as well as analytical tools such as digital views of the signal, bus views, packet decoding, search tools, and packet decode tables with time stamp information.
DPO3COMP	Computer Serial Triggering and Analysis Module. Enables triggering on packet level information on RS-232/422/485/UART buses as well as analytical tools such as digital views of the signal, bus views, packet decoding, search tools, and packet decode tables with time stamp information.
DPO3PWR	Power Analysis Application Module. Enables quick and accurate analysis of power quality, switching loss, harmonics, safe operating area (SOA), modulation, ripple, and slew rate (dI/dt, dV/dt).
DPO3VID	HDTV and Custom (nonstandard) Video Triggering Module

*1 Not available on 2-channel models.

Instrument Options

Power Plug Options

Option	Description
Opt. A0	North America
Opt. A1	Universal Euro
Opt. A2	United Kingdom
Opt. A3	Australia
Opt. A5	Switzerland
Opt. A6	Japan
Opt. A10	China
Opt. A11	India
Opt. A99	No power cord

Language Options*2

Option	Description
Opt. L0	English manual
Opt. L1	French manual
Opt. L2	Italian manual
Opt. L3	German manual
Opt. L4	Spanish manual
Opt. L5	Japanese manual
Opt. L6	Portuguese manual
Opt. L7	Simplified Chinese manual
Opt. L8	Traditional Chinese manual
Opt. L9	Korean manual
Opt. L10	Russian manual
Opt. L99	No manual

*2 Language options include a translated front-panel overlay for the selected language(s).

Service Options*3

Option	Description
Opt. C3	Calibration Service 3 years
Opt. C5	Calibration Service 5 years
Opt. CA1	Provides a single calibration event, or coverage for the designated calibration interval, whichever comes first
Opt. D1	Calibration Data Report
Opt. D3	Calibration Data Report 3 years (with Opt.C3)
Opt. D5	Calibration Data Report 5 years (with Opt.C5)
Opt. R5	Repair Service 5 years (including warranty)

*3 Probes and accessories are not covered by the oscilloscope warranty and service offerings. Refer to the datasheet of each probe and accessory model for its unique warranty and calibration terms.

Recommended Probes

Probe	Description
TAP1500	1.5 GHz TekVPI® active voltage probe
TDP0500	500 MHz TekVPI differential voltage probe with ± 42 V differential input voltage
TDP1000	1 GHz TekVPI differential voltage probe with ± 42 V differential input voltage
TCP0030	120 MHz TekVPI 30 Ampere AC/DC current probe
TCP0150	20 MHz TekVPI 150 Ampere AC/DC current probe
TCPA300/400*4	Current measurement systems
P5200	1.3 kV, 25 MHz high-voltage differential probe
P5205*4	1.3 kV, 100 MHz high-voltage differential probe
P5210*4	5.6 kV, 50 MHz high-voltage differential probe
P5100	2.5 kV, 100X high-voltage passive probe
ADA400A*4	100X, 10X, 1X, 0.1X high-gain differential amplifier
DPO3PWRBND Power Solution Bundle	Includes P5205 and TDP0500 differential voltage probes, TCP0030 current probe, TPA-BNC adapter, deskew pulse generator (TEK-DPG), deskew fixture, and power analysis module (DPO3PWR) in a hard-sided carrying case. Bundle discount reflected in price.

*4 Requires TekVPI® to TekProbe BNC adapter (TPA-BNC).

Recommended Accessories

Accessory	Description
Service Manual	071-2422-xx (English only)
SIGEXPTE	NI LabVIEW SignalExpress Tektronix Edition Software
TPA-BNC	TekVPI to TekProbe BNC adapter
TekVPI® External Power Supply*5	119-7465-xx
TEK-USB-488	GPIO to USB adapter
Soft Transit Case	ACD4000
Hard Transit Case	HCTEK4321 (requires ACD4000)
Rackmount Kit	RMD3000
TEK-DPG	Deskew Pulse Generator
067-1686-00	Deskew Fixture

*5 Required when total oscilloscope probe power usage exceeds 20 W.

Warranty

Three-year warranty covering all parts and labor, excluding probes.



Product(s) are manufactured in ISO registered facilities.



Product(s) complies with IEEE Standard 488.1-1987, RS-232-C, and with Tektronix Standard Codes and Formats.

Contact Tektronix:

ASEAN / Australasia (65) 6356 3900
Austria +41 52 675 3777
Balkans, Israel, South Africa and other ISE Countries +41 52 675 3777
Belgium 07 81 60166
Brazil +55 (11) 40669400
Canada 1 (800) 661-5625
Central East Europe, Ukraine, and the Baltics +41 52 675 3777
Central Europe & Greece +41 52 675 3777
Denmark +45 80 88 1401
Finland +41 52 675 3777
France +33 (0) 1 69 86 81 81
Germany +49 (221) 94 77 400
Hong Kong (852) 2585-6688
India (91) 80-42922600
Italy +39 (02) 25086 1
Japan 81 (3) 6714-3010
Luxembourg +44 (0) 1344 392400
Mexico, Central/South America & Caribbean 52 (55) 54247900
Middle East, Asia, and North Africa +41 52 675 3777
The Netherlands 090 02 021797
Norway 800 16098
People's Republic of China 86 (10) 6235 1230
Poland +41 52 675 3777
Portugal 80 08 12370
Republic of Korea 82 (2) 6917-5000
Russia & CIS +7 (495) 7484900
South Africa +27 11 206 8360
Spain (+34) 901 988 054
Sweden 020 08 80371
Switzerland +41 52 675 3777
Taiwan 886 (2) 2722-9622
United Kingdom & Ireland +44 (0) 1344 392400
USA 1 (800) 426-2200

For other areas contact Tektronix, Inc at: 1 (503) 627-7111

Updated 30 October 2008

For Further Information. Tektronix maintains a comprehensive, constantly expanding collection of application notes, technical briefs and other resources to help engineers working on the cutting edge of technology. Please visit www.tektronix.com



Copyright © Tektronix, Inc. All rights reserved. Tektronix products are covered by U.S. and foreign patents, issued and pending. Information in this publication supersedes that in all previously published material. Specification and price change privileges reserved. TEKTRONIX and TEK are registered trademarks of Tektronix, Inc. All other trade names referenced are the service marks, trademarks, or registered trademarks of their respective companies.

12 Dec 2008

3GW-21364-1

