

# Agilent PNA Series Microwave Network Analyzers

## Configuration Guide

<b>PNA-L N5230A</b>	<b>300 kHz to 6, 13.5, or 20 GHz</b>
<b>PNA-L N5230A</b>	<b>10 MHz to 20, 40, or 50 GHz</b>
<b>PNA E8362B</b>	<b>10 MHz to 20 GHz</b>
<b>PNA E8363B</b>	<b>10 MHz to 40 GHz</b>
<b>PNA E8364B</b>	<b>10 MHz to 50 GHz</b>
<b>PNA E8361A</b>	<b>10 MHz to 67 GHz</b>
<b>PNA N5250A</b>	<b>10 MHz to 110 GHz</b>

### System configuration summary

This summary lists the main components required to form a basic measurement system. Options or peripherals may be added to provide enhanced measurement and data storage capability.

### Full S-parameter measurements

- **Agilent PNA Series microwave network analyzers**
- **Test port cables, 50 ohms**
- **Calibration kit for applicable connector type**

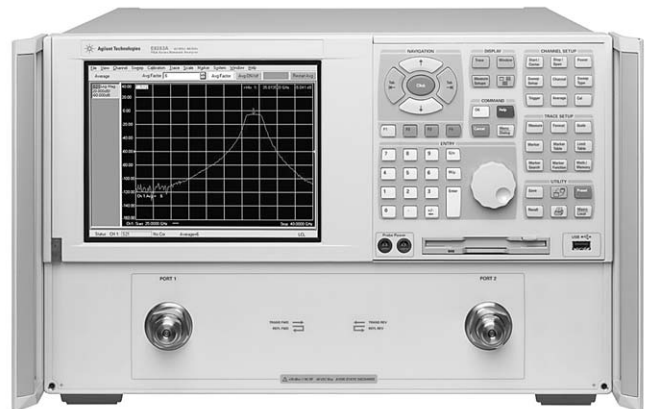

This configuration guide describes standard configurations, options, accessories, upgrade kits and compatible peripherals for the PNA Series microwave network analyzers. This guide should be used with the *Agilent PNA Series Microwave Network Analyzers, Data Sheet* for a complete description of these analyzers.

# PNA-L (N5230A)

---

## Step 1: Select N5230A model number

---

### Step 2: Choose your frequency range and test set (Mandatory, choose only one)

Description	Ordering number
300 kHz to 6 GHz 2-port standard test set	N52300-020
300 kHz to 6 GHz 2-port configurable test set and extended power range	N52300-025
300 kHz to 13.5 GHz 2-port standard test set	N52300-120
300 kHz to 13.5 GHz 2-port configurable test set and extended power range	N52300-125
10 MHz to 20 GHz 2-port standard test set	N52300-220
10 MHz to 20 GHz 2-port configurable test set and extended power range	N52300-225
300 kHz to 20 GHz 4-port standard test set	N52300-240
300 kHz to 20 GHz 4-port configurable test set and extended power range	N52300-245
10 MHz to 40 GHz 2-port standard test set	N52300-420
10 MHz to 40 GHz 2-port configurable test set and extended power range	N52300-425
10 MHz to 50 GHz 2-port standard test set	N52300-520
10 MHz to 50 GHz 2-port configurable test set and extended power range	N52300-525

---

### Step 3: Choose additional software options (Optional)

Description	Ordering number
Time domain for 6 GHz model	N52310-010
Time domain for 13.5, 20, 40 or 50 GHz model	N52300-010
Frequency-offset measurements	N52300-080

---

### Step 4: Choose an electronic or mechanical calibration kit (Optional)

Description	Ordering number
300 kHz to 9 GHz, 2-port, 3.5 mm	85093C
300 kHz to 13.5 GHz, 4-port, Type-N or 3.5 mm connectors	N4431B
300 kHz to 18 GHz, 4-port Type-N	N4432A
300 kHz to 20 GHz, 4-port 3.5 mm	N4433A
300 kHz to 26.5 GHz, 2-port 3.5 mm connectors	N4691B
10 MHz to 50 GHz, 2-port 2.4 mm connectors	N4693A

Note: For additional calibration kits refer to page 16

---

### Step 5: Accessories (Optional)

Description	Ordering number
Rack mount kit without handles	N5230A-1CM
Rack mount kit with handles	N5230A-1CP
USB CD R/W drive	N4688A
USB Hub	N4689A

Note: For additional accessories refer to page 16

---

### Step 6: Calibration documentation (Optional)

Description	Ordering number
ISO 17025 compliant calibration	N5230A-1A7
Commercial calibration certificate with test data	N5230A-UK6
ANSI Z540 compliant calibration	N5230A-A6J

---

### Step 7: Choose your warranty and service (Optional)

Description
1 year return-to Agilent warranty and service
3 year return-to Agilent warranty and service

### Documentation

The PNA Series instruments are equipped with an Online Help system available within the instrument in the following languages: English, Japanese, Chinese, German, Spanish, and French. The PNA Service Guide and Online Help system are available on the Web:

[www.na.tm.agilent.com/pna](http://www.na.tm.agilent.com/pna)

### Connector type

Option 020, 025, 120, 125, 220, 225, 240, 245:

3.5 mm ruggedized male, 50 ohm

Option 420, 425, 520, 525:

2.4 mm ruggedized male, 50 ohm

### Additional product information

For additional PNA-L (N5230A) product information, refer to the PNA-L brochure available on our Web site:

[www.agilent.com/find/pnal](http://www.agilent.com/find/pnal)

# PNA-L (N5230A)

This guide is intended to assist you in the ordering process. Additional information and products (such as calibration kits and cables) are described throughout this document.

## Test set options

- Standard test set and power range (Option xx0)**  
 The 20 GHz version is available in 2- or 4-ports.
- Configurable test set and extended power range (Option xx5)**  
 Adds six front panel access loops and two 60 dB step attenuators as shown in the figures below. This provides the capability to improve instrument sensitivity for measuring low-level signals, to reverse the directional couplers to achieve even more dynamic range or to add components and other peripheral instruments for a variety of measurement applications. The 20 GHz version is available in 2- or 4-ports.

### 2-port standard test set

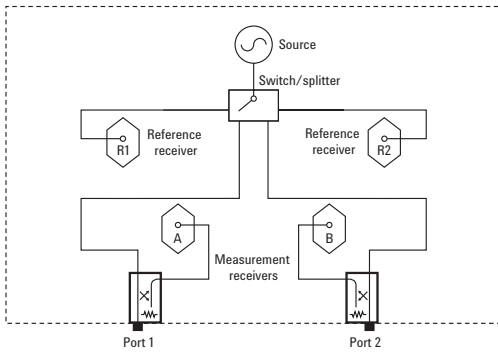

### 2-port configurable test set and extended power range

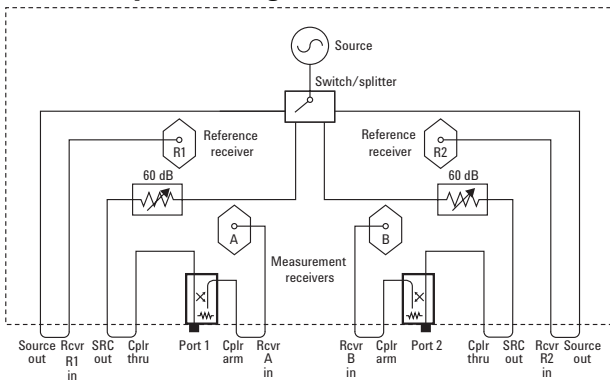

### 4-port standard test set

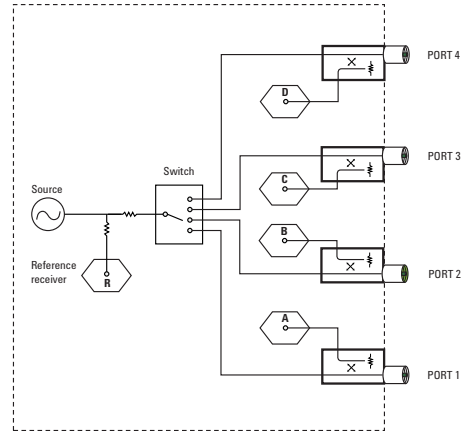

### 4-port configurable test set and extended power range

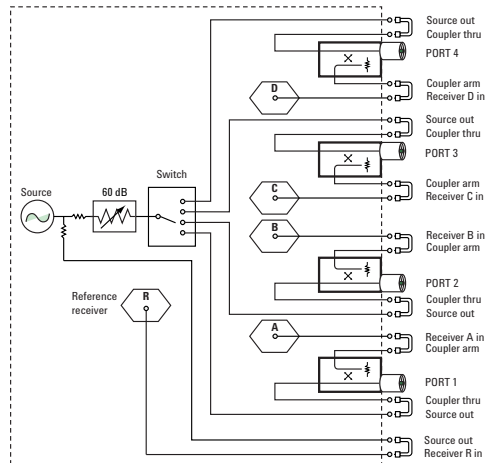

# PNA-L (N5230A)

## ***Additional options***

### **Time domain (Option 010)**

This option enables the PNA Series to view reflection and transmission responses in both time or distance domain. Use time domain to tune filters, gate out the response of fixtures and cables, characterize the impedance of transmission line, and more.

### **Frequency offset (Option 080)**

This option enables the PNA Series to set the source frequency independently from where the receivers are tuned. This ability is important for two general classes of devices: mixers (and converters) and amplifiers.

### **4-port measurement application (Option 550)**

Enables full, 4-port error correction and differential measurements on a 2-port network analyzer. External test set required. User installable.

## ***Certification options***

### **Commercial calibration certification with test data (Option UK6)**

Complete set of measurements which test unit to manufacturer's published specifications. Includes calibration label, calibration certificate, and data report. Conforms to ISO 9001.

### **ISO 17025 compliant calibration (Option 1A7)**

Complete set of measurements which tests unit to manufacturer's published specifications. Includes calibration label, ISO17025 calibration certificate, and data report, measurement uncertainties and guardbands on all customer specifications. Conforms to ISO 17025 and ISO 9001.

# PNA Network Analyzers<sup>1</sup>

## E8361A/62B/63B/64B, N5250A

### PNA (highest performance series)

E8362B	10 MHz to 20 GHz
E8363B	10 MHz to 40 GHz
E8364B	10 MHz to 50 GHz
E8361A	10 MHz to 67 GHz
N5250A <sup>2</sup>	10 MHz to 110 GHz

### Options

To add options to a product, order the corresponding item number.

	Description	For E8362B	For E8363B	For E8364B	For E8361A	For N5250A system <sup>3</sup>	Additional information
<b>Test set</b>							
Option 014	• Configurable test set	E8362B-014	E8363B-014	E8364B-014	E8361A-014	Included	
<b>Power configuration</b>							
Option UNL	• Extended power range and bias-tees	E8362B-UNL	E8364B-UNL	E8364B-UNL	E8361A-UNL	Included	Only E8361A requires 014
Option 016	• Add receiver attenuators	E8362A-016	E8364A-016	E8364A-016	E8361A-016	E8361A-016	Requires UNL (only E8361A also requires 014)
Option H85	• High-power configuration	E8362B-H85	E8363B-H85	E8364B-H85	Contact Agilent	Contact Agilent	Includes 014, 016, UNL <sup>4</sup> , 080, 081
<b>Non-linear measurements</b>							
Option 080	• Frequency offset	E8362A-080	E8364A-080	E8364A-080	E8361A-080	Included	Requires 014 (E8361A only, 081 required if UNL is also purchased)
Option 081	• Reference receiver switch	E8362A-081	E8364A-081	E8364A-081	E8361A-081	Included	Requires 014, 080 (only E8361A also requires UNL)
Option 083	• Frequency converter measurement application	E8362A-083	E8364A-083	E8364A-083	E8361A-083	E8361A-083	Requires 014, 080, 081 (only E8361A also requires UNL) includes GPIB to USB interface (82357A)
<b>Pulse, antenna, mm-wave</b>							
Option H08 <sup>5</sup>	• Pulsed-RF measurement capability	E8362B-H08	E8363B-H08	E8364B-H08	E8361A-H08	E8361A-H08	
Option H11	• IF access (for antenna, pulsed-RF and mm-wave measurements)	E8362B-H11	E8363B-H11	E8364B-H11	E8361A-H11	Included	Requires 014, UNL, 080, and 081
<b>Measurement features</b>							
Option 010	• Time-domain capability	E8362A-010	E8363A-010	E8364A-010	E8361A-010	E8361A-010	Option 550 not compatible with N5250A systems
Option 550	• 4-port measurement application	E8362B-550	E8363B-550	E8364B-550	E8361A-550		
<b>Accessories</b>							
Option 1CM	• Rack mount kit for use without handles	E8362A-1CM	E8363A-1CM	E8364A-1CM	E8361A-1CM	E8361A-1CM	
Option 1CP	• Rack mount kit for use with handles	E8362A-1CP	E8363A-1CP	E8364A-1CP	E8361A-1CP	E8361A-1CP	
N4688A	• USB CD R/W drive	N4688A	N4688A	N4688A	N4688A	N4688A	
N4689A	• USB Hub	N4689A	N4689A	N4689A	N4689A	N4689A	
<b>Calibration documentation</b>							
Option 1A7	• ISO 17025 compliant calibration	E8362B-1A7	E8363B-1A7	E8364B-1A7	E8361A-1A7	E8361A-1A7	
Option UK6	• Commercial calibration certificate with test data	E8362A-UK6	E8363A-UK6	E8364A-UK6	E8361A-UK6	E8361A-UK6	
Option A6J	• ANSI Z540 compliant calibration	E8362B-A6J	E8363B-A6J	E8364B-A6J	E8361A-A6J	E8361A-A6J	

**Note:** Item numbers may not correspond to product model number. For example, to order the time-domain option on the E8362B, the correct item number to order is E8362A-010.

### Warranty and service

One, and three year warranty service plans are available at time of instrument purchase. The N5250A 110 GHz system carries a full one-year on-site warranty (where available).

### Calibration

Three year calibration plans are available at time of instrument purchase.

- All models are not available in all countries.
- For more detailed information regarding the 110 GHz network analyzer system, refer to the Agilent Web site: [www.agilent.com/find/pna](http://www.agilent.com/find/pna) and download the N5250A Technical Overview, literature number 5988-9620EN.
- The N5250A 110 GHz system also includes an N5260A millimeter-wave test set controller, 1.0 mm combiner assembly, interconnecting cables, and installation and productivity assistance. See page 12 for more details.
- UNL\* does not include bias-tees. Only includes source attenuators.
- Up to 67 GHz.

# Agilent PNA Network Analyzers

The microwave PNA Series instruments are integrated vector network analyzers equipped with a built-in S-parameter test set, synthesized source, hard and floppy disk drives, and LCD display. The E8362B analyzer has two 50 ohm, 3.5 mm (m) test ports. The E8363B and E8364B analyzers have two 50 ohm, 2.4 mm (m) test ports. The E8361A analyzer has two 50 ohm, 1.85 mm (m) test ports. Included with each instrument is a mouse, keyboard (U.S.), CD-ROM containing a copy of on-line Help and programming documentation, and a 1-year return-to-Agilent service warranty.

- **E8362B** network analyzer, 10 MHz to 20 GHz
- **E8363B** network analyzer, 10 MHz to 40 GHz
- **E8364B** network analyzer, 10 MHz to 50 GHz
- **E8361A** network analyzer, 10 MHz to 67 GHz<sup>1</sup>
- **N5250A** network analyzer system, 10 MHz to 110 GHz

## Options

### □ **Time-domain capability (Option 010)**

For viewing reflection and transmission responses in time or distance domain.

### □ **Configurable test set (Option 014)<sup>2</sup>**

Provides six front panel access loops. Three access loops are for port one and three for port two. The loops provide access to the signal path between (a) the source output and the reference receiver, (b) the source output and directional coupler thru arm and (c) the coupled arm of the directional coupler and the port receiver. This option provides the capability to improve instrument sensitivity for measuring low-level signals, to reverse the directional coupler to achieve even more dynamic range or to add components and other peripheral instruments for a variety of measurement applications. (see PNA Series Microwave Data Sheet literature number 5988-7988EN for a basic block diagram)

### □ **4-port measurement application (Option 550)<sup>3</sup>**

Enables full, 4-port error correction and differential measurements on a 2-port network analyzer. External test set required.

### □ **Extended power range and bias-tees (Option UNL)<sup>2</sup>**

Adds two 60 dB step attenuators and two bias-tees to the E8362/3/4B. Adds two 50 dB step attenuators and two bias-tees to the E8361A. A step attenuator and bias-tee set is inserted between the source and test port one and another set between the source and test port two. (see PNA Series Microwave Data Sheet literature number 5988-7988EN for a basic block diagram)

### □ **Frequency offset (Option 080)<sup>2</sup>**

This option enables the PNA Series microwave network analyzers to set the source frequency independently from where the receivers are tuned. This ability is important for two general classes of devices: mixers (and converters) and amplifiers. Option 080 provides a very basic user interface.

### □ **Reference receiver switch (Option 081)<sup>2</sup>**

Option 081 adds a solid-state internal RF transfer switch in the R1 reference-receiver path (see PNA Series Microwave Data Sheet literature number 5988-7988EN for a basic block diagram). The switch allows the instrument to easily switch between standard S-parameter (non-frequency-offset) measurements and frequency offset measurements such as relative phase or absolute group delay that require an external reference mixer. The user can set the switch manually or remotely, but it is best used with the frequency-converter application (Option 083), where it is controlled automatically during the vector-mixer calibration procedure and subsequent measurements.

### □ **Frequency-converter measurement application (Option 083)<sup>2</sup>**

The frequency-converter application adds an intuitive and easy-to-use user interface, advanced calibration choices that provide exceptional amplitude and phase accuracy, and control of external signal sources for use as local oscillators. Mixer calibration techniques include scalar-mixer calibration and vector-mixer calibration (requires Option 081). Finally, the frequency-converter application supports all of Agilent's major signal source families. Option 083 includes a GPIB to USB interface (82357A) for control of external sources and power meters.

1. The E8361A can be extended to 110 GHz with IF access (Option H11).

2. Up to 67 GHz.

3. Not compatible with N5250A.

❑ **Add receiver attenuators (Option 016)** An attenuator is added between each test port and its corresponding receiver. Two 35 dB step attenuators are added to the E8362/3/4B. Two 50 dB step attenuators are added to the E8361A (see PNA Series Microwave Data Sheet literature number 5988-7988EN for a basic block diagram).

❑ **Pulsed-RF measurement capability (Option H08)**<sup>2</sup> Provides software to set up and control pulsed-RF measurements with point-in-pulse capability. The software sets the coefficient of the PNA's digital-IF filter to null out unwanted spectral components, enables the IF gates provided with IF access (Option H11), and controls selected Agilent pulse generators. It can be run on the PNA or an external computer. A ".dll" file containing the IF-filter algorithms is included for automated pulsed-RF testing. The pulsed application is configured to work with the Agilent 81110A series pulse generator.

For more detailed information regarding pulsed measurement capabilities with the microwave PNA refer to the Agilent Web site [www.agilent.com/find/pna](http://www.agilent.com/find/pna) and download the *PNA Series MW Network Analyzers Configuration Guide for Pulsed Measurements*, literature number 5988-9833EN.

❑ **IF access (Option H11)** Provides hardware to enable antenna, point-in pulse, and broadband millimeter-wave measurements to 110 GHz. For each of the MW PNA's measurement receivers, IF gates (enabled with pulsed measurement capability, Option H08) and external IF inputs are added. In addition, access to the PNA's internal RF and LO source is provided for remote mixing applications. For basic antenna measurements, only Option H11 is necessary. Pulsed antenna applications also require the pulsed measurement capability (Option H08). Broadband measurements to 110 GHz, also requires an N5260A millimeter-wave test set controller.

Note: Use external IF access for up to 20 dB more sensitivity when making antenna measurements with a remote mixing configuration. Add Option H08 (Pulsed-RF Measurement Capability) to enable advanced pulsed measurements. Or upgrade to a broadband (10 MHz to 110 GHz) VNA system simply by purchasing an N5260A controller test set with test heads (Option 110, 120, or 130).

❑ **High-power test set (Option H85)** This configuration combines options that are often necessary for high power measurements (UNL\*<sup>1</sup>, 014, 016, 080, 081). The only difference between ordering Option H85 versus a combination of the options listed above is the source attenuator option UNL. Standard UNL includes two source attenuators and two bias-tees. Option H85 includes the two source attenuators, but not the bias-tees, as the bias-tees are the power-limiting factor in the network analyzer test set. The maximum power at the test port is +43 dBm (<20 GHz), and +40 dBm (>20 GHz).

Option 080, frequency-offset mode, is included in option H85 because it manages the phase-locking internally (instead of depending on the R1 receiver). So if you need to use external components in the path of the R1 receiver, it makes the measurements simpler and more robust.

❑ **Rack mount kit without handles (Option 1CM)**  
Adds a rack mount (5063-9217) and rail kit (E3663AC) for use without handles.

❑ **Rack mount kit with handles (Option 1CP)**  
Adds a rack mount (5063-9237)<sup>3</sup> and rail kit (E3663AC) for use with standard supplied handles.

## Documentation

PNA Online Help system is available within PNA instruments in the following languages: English, German, Spanish, French, Japanese, and Chinese.

The PNA Service Guide and Online Help are available on the Web: <http://na.tm.agilent.com/pna>

1. UNL\* does not include bias-tees. Only includes source attenuators.

2. Up to 67 GHz.

3. The 5063-9237 kit assumes you have the standard handles shipped with the instrument. If you do not have handles, order a 5063-9224 kit.



## **Certification options**

### **❑ Commercial calibration certificate with test data (Option UK6)**

Complete set of measurements which tests unit to manufacturer's published specifications. Includes calibration label, calibration certificate, and data report. Conforms to ISO 9001.

### **❑ ISO 17025 compliant calibration (Option 1A7)**

Complete set of measurements which tests unit to manufacturer's published specifications. Includes calibration label, ISO 17025 calibration certificate, and data report, measurement uncertainties and guardbands on all customer specifications. Conforms to ISO 17025 and ISO 9001.

### **❑ ANSI Z540 compliant calibration (Option A6J)**

Complete set of measurements which tests unit to manufacturer's published specifications. Includes pre and post-adjustment data with measurement uncertainty information compliant to the ANSI/NCSL Z540 standard.

## **Warranty and service**

1 and 3 year warranty and service plans are available at time of instrument purchase. Standard warranty is 1 year.

## **Calibration**

3 year calibration plans are available at time of instrument purchase. Contact your local Agilent sales office for details.

## **Product services**

Agilent product services provide tailored assistance related to a specific need or application. Product services enable you to quickly learn how Agilent instruments operate, their capabilities, and how to apply that knowledge to achieve your specific measurement goals.

PNA series services available include:

- Remote scheduled productivity assistance
- 1 Day of start-up assistance
- Daily productivity assistance
- PNA operator training for 8 students at your business site
- PNA operator web classes for 1 student
- Custom services to be qualified by an Agilent technical consultant

# **E8361A/62B/63B/64B Configuration Details**

## **Selecting the correct mixer-test configuration:**

Most mixer or converter test applications require Options 014, 080, 081, and 083. If you want to create and automate your own custom frequency-offset measurements (for example, intermodulation distortion), you may only need Options 014 and 080. For converters that require input power below -27 dBm, or for devices that have a large amount of LO feedthrough (like an unfiltered mixer), Option UNL, which adds source attenuators, is highly recommended. Besides allowing lower input power levels, these attenuators improve the isolation between the PNA's internal source and LO leakage signals, helping to prevent source-unleveled errors. For devices that put out signals near or above the receiver's compression levels (which varies between -3 and +5 dBm, depending on the model and frequency), Option 016 is recommended, which adds receiver attenuators. Finally, Option 010, which adds time-domain analysis, is very useful for gating out unwanted, time-delayed responses which often occur when measuring mixers.



# Microwave PNA Network Analyzer

## Simplified test set block diagrams

### Standard power range

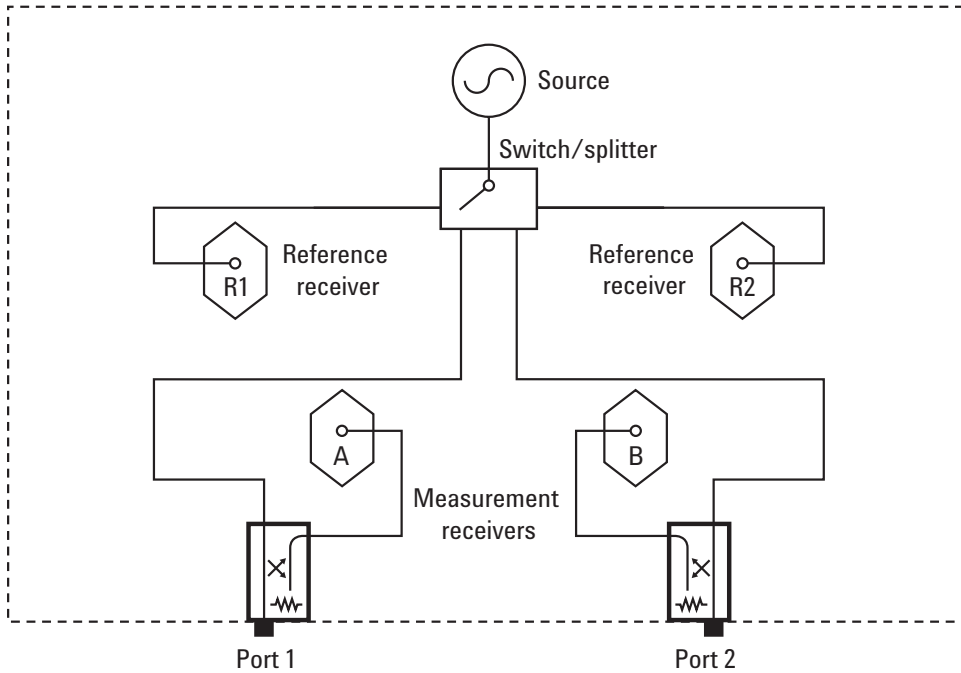

### Extended power range and bias-tees (Option UNL)

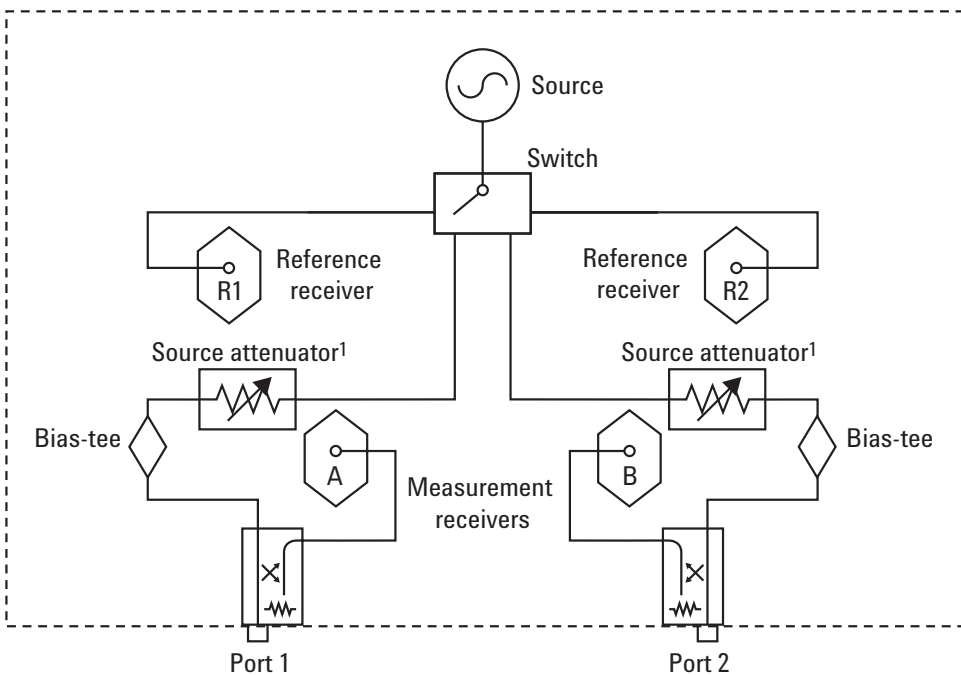

1. Source attenuator for E8362/3/4B is 60 dB in 10 dB steps.  
Source attenuator for E8361A is 50 dB in 10 dB steps.

# Microwave PNA Network Analyzer

## Simplified test set block diagrams – continued

### Configurable test set (Option 014)

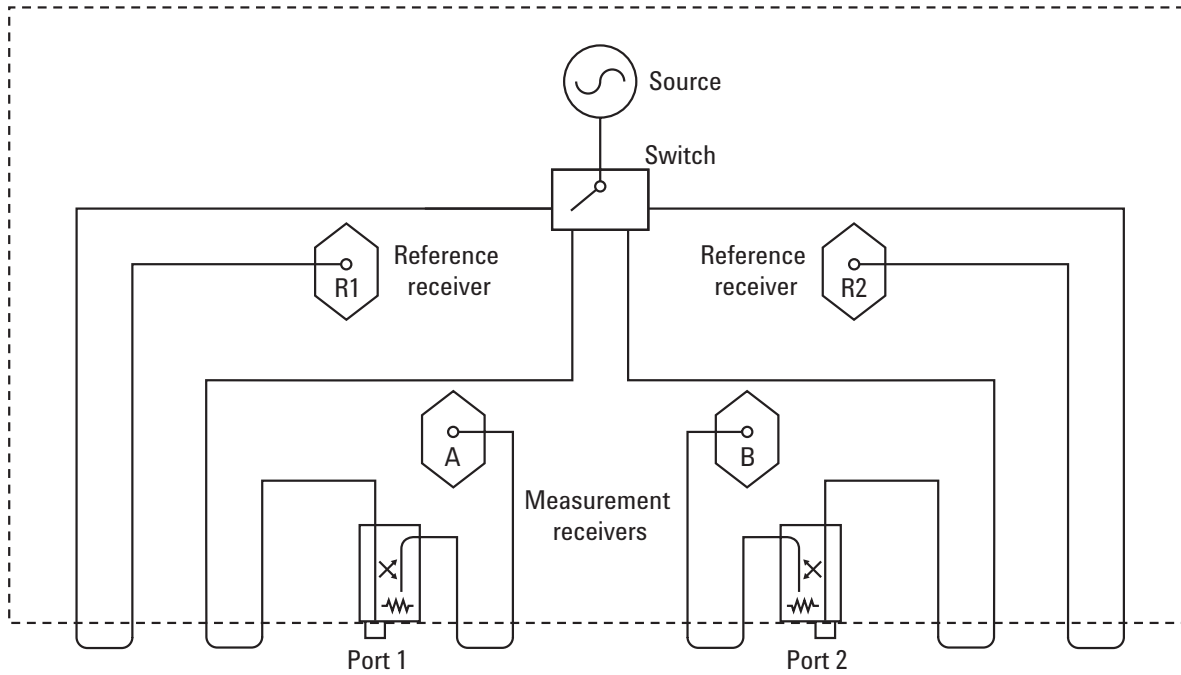

### Configurable test set with extended power range and bias-tees (Option UNL and 014)

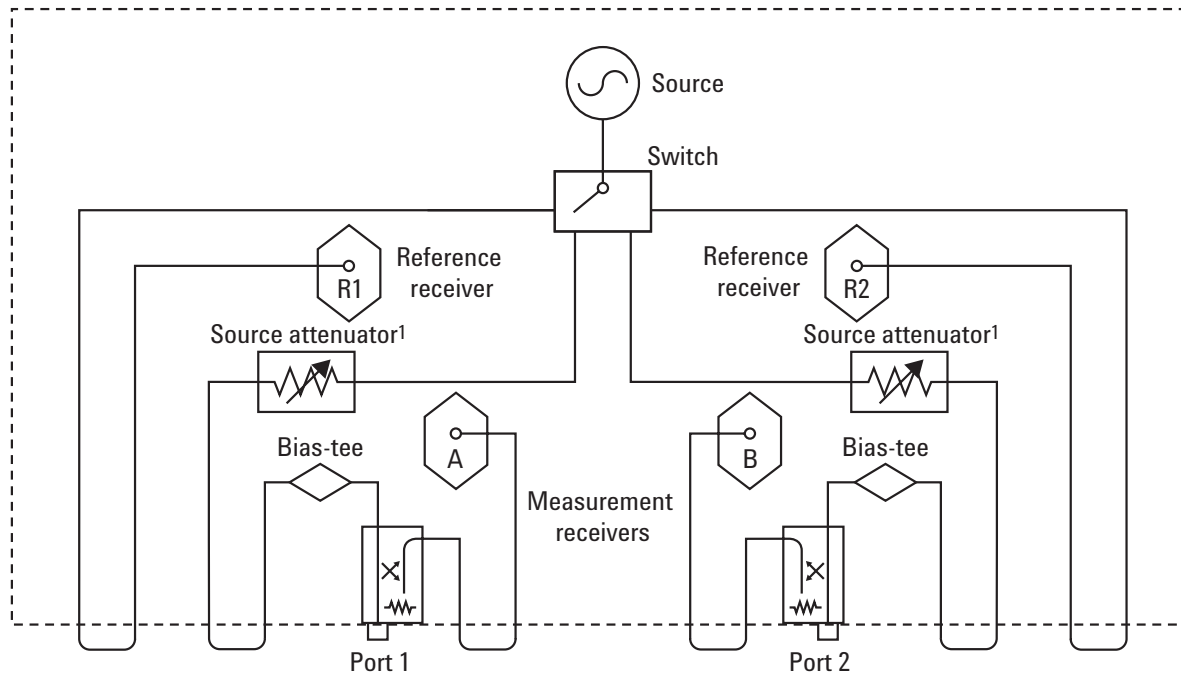

1. Source attenuator for E8362/3/4B is 60 dB in 10 dB steps.  
Source attenuator for E8361A is 50 dB in 10 dB steps.

# Microwave PNA Network Analyzer

## Simplified test set block diagrams – continued

Fully optional, active device or mixer/converter test configuration (Options 014, UNL, 016, 080, 081)

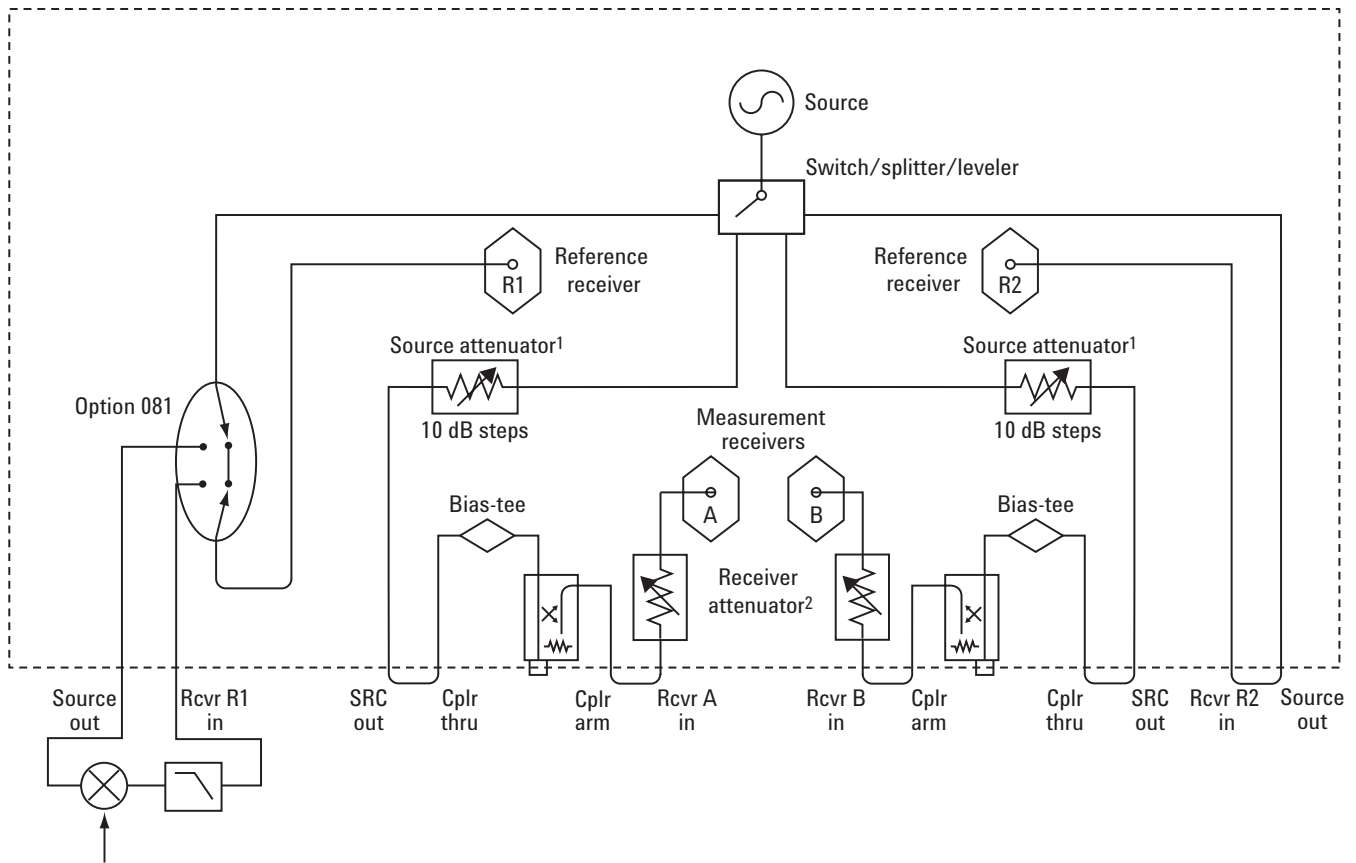

1. Source attenuator for E8362/3/4B is 60 dB in 10 dB steps. Source attenuator for E8361A is 50 dB in 10 dB steps.
2. Receiver attenuator for E8362/3/4B is 35 dB in 5 dB steps. Receiver attenuator for E8361A is 50 dB in 10 dB steps.



# Microwave PNA Network Analyzer

## Simplified test set block diagrams – continued

Fully optioned, pulse-RF, antenna, or mm-wave configuration  
(Options 014, UNL, 016, 080, 081, H11)

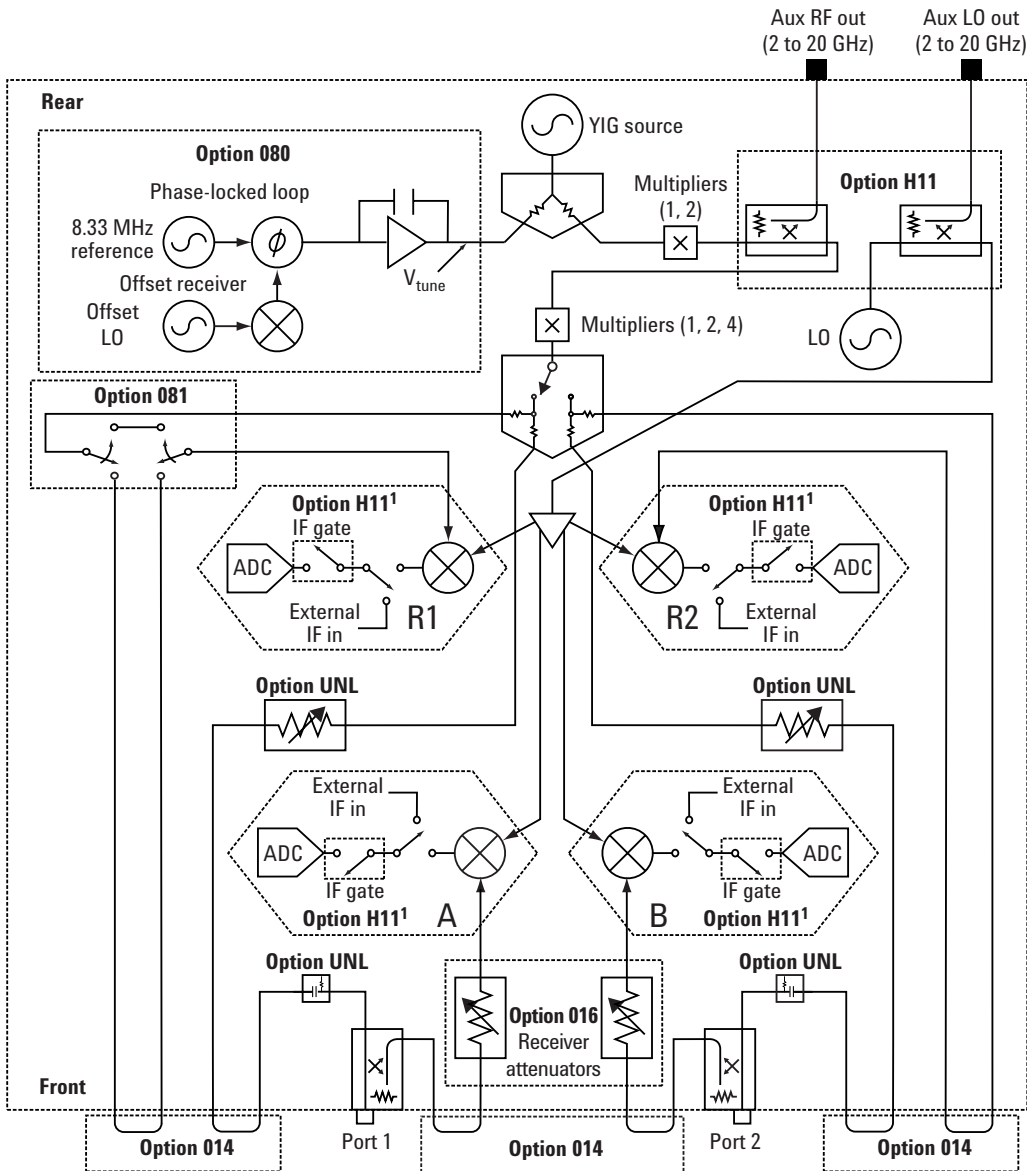

1. Option H11: IF-gate controls and external-IF inputs are accessed on rear panel. IF gates are enabled with Option H08. External-IF input frequency is 8.33 MHz.

# N5250A Configuration Details

## □ N5250A MW PNA system<sup>1</sup>, 10 MHz to 110 GHz, includes: *E8361A MW PNA with IF access (Option H11)*

- Configurable test set – Option 014 (required)
- Extended power range and bias-tees – Option UNL (required)
- Frequency-offset mode – Option 080 (required)
- Reference channel switch – Option 081 (required)

## *N5260A millimeter-wave test set controller with test heads*

- 67 GHz test heads
- 1.0 mm combiner assembly
- Interconnecting cables
- Installation and productivity assistance

## Additional options available:

- Millimeter-wave modules with bias-tees - Option 017
- Millimeter-wave modules with bias-tees and port 2 attenuator - Option 018
- Receiver attenuator – Option 016
- Time-domain capability – Option 010
- Extended memory (512 MB) – Option 022
- Pulsed-RF measurement capability – Option H08<sup>2</sup>
- Frequency converter application – Option 083<sup>2</sup>

Factory integration of the N5250A system integrates the E8361A with Option H11 and the N5260A millimeter-wave controller with test heads. On-site installation is included, and the entire system carries a full one-year, on-site warranty (where available).

## Option Descriptions

### □ Millimeter-wave modules with bias-tees (Option 017)

Adds 67 GHz bias-tees to the combiner assembly between the input to the combiner and the 67 GHz coupler. The bias-tees have tri-axial connectors for force, sense, and ground. Positioning the bias-tees close to the DUT greatly improves stability for on-wafer and in-fixture devices. The bias-tees added for this option have a voltage rating of 40 volts and a maximum of 0.5 amps.

### □ Millimeter-wave modules with bias-tees and port 2 attenuator (Option 018)

Adds 67 GHz bias-tees to the combiner assembly between the input to the combiner and the 67 GHz coupler. The bias-tees have tri-axial connectors for force, sense, and ground. Positioning the bias-tees close to the DUT greatly improves stability for on-wafer and in-fixture devices. The bias-tees added for this option have a voltage rating of 40 volts and a maximum of 0.5 amps. Additionally, Option 018 adds a 25 dB micrometer attenuator to the port 2 test head.

## **Banded waveguide solution**

In order to assemble a banded waveguide solution, the following components are needed:

- Microwave PNA network analyzer (E8361A or E8362/3/4B) with the following options:
  - IF access - Option H11
  - Configurable test set - Option 014
  - Extended power range and bias-tees - Option UNL
  - Frequency-offset mode - Option 080
  - Reference channel switch - Option 081
- Millimeter-wave test set controller (N5260A) with no options
- A set of waveguide modules:
  - N5260AW15, 50 to 75 GHz
  - N5260AW12, 60 to 90 GHz
  - N5260AW10, 75 to 110 GHz
  - N5260AW08, 90 to 140 GHz
  - N5260AW06, 110 to 170 GHz
  - N5260AW05, 140 to 220 GHz
  - N5260AW03, 220 to 325 GHz

NOTE: To significantly improve system dynamic range above 220 GHz, Agilent strongly recommends adding two external synthesizers such as Agilent's PSG Series signal generators; one for the RF signal, and one for the LO signal.

For more detailed information, see *PNA Millimeter-wave Technical Overview*, literature number 5988-9620EN.

## **On-wafer applications**

For on-wafer applications, Cascade Microtech<sup>3</sup> provides complete probing systems using the N5250A. These include both new probing systems and upgrades to existing Cascade Microtech products. Cascade can also provide on-wafer verification and probing system training. Once the N5250A system is verified in coax, Cascade Microtech will verify the system through its wafer probes.

1. For more detailed information regarding the 110 GHz network analyzer system, refer to the Agilent Web site: [www.agilent.com/find/pna](http://www.agilent.com/find/pna) and download the N5250A Technical Overview, literature number 5988-9620EN.

2. Up to 67 GHz.

3. Cascade Microtech is an Agilent Channel Partner.

# N5250A Millimeter-Wave PNA Block Diagram

With Option 017, the signal is routed out of the PNA from the front panel jumpers rather than the ports. Without Option 017, the signal is routed from the front panel ports to the combiner assembly, allowing access to the PNA's internal bias-tees.

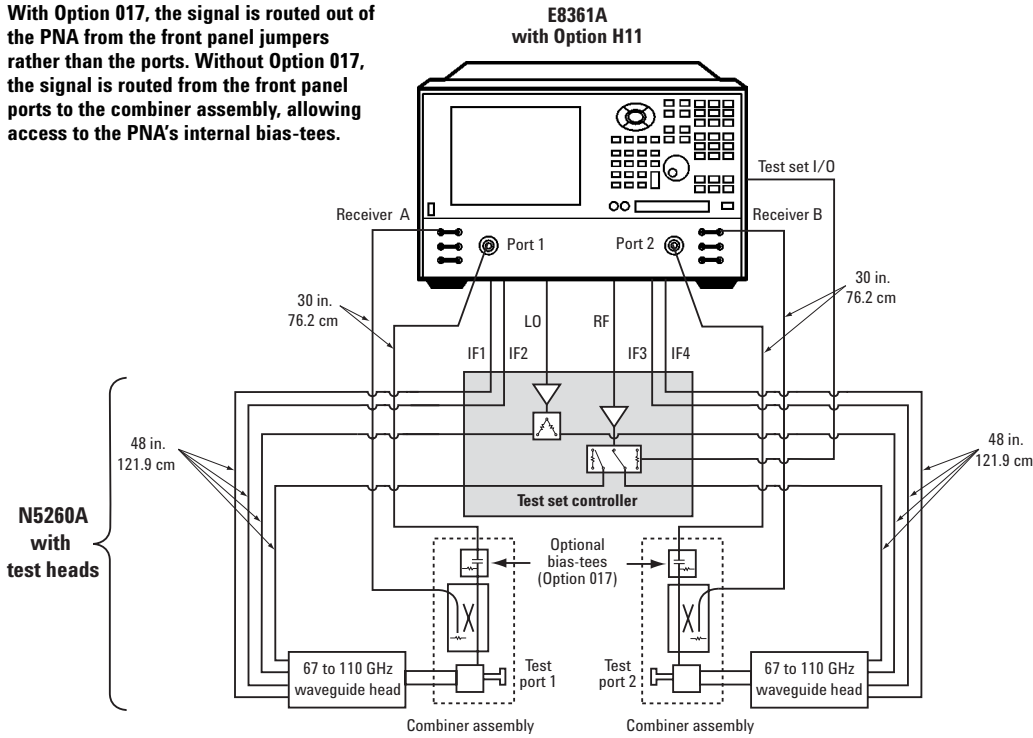

PNA test set block diagram

Simplified receiver block diagram

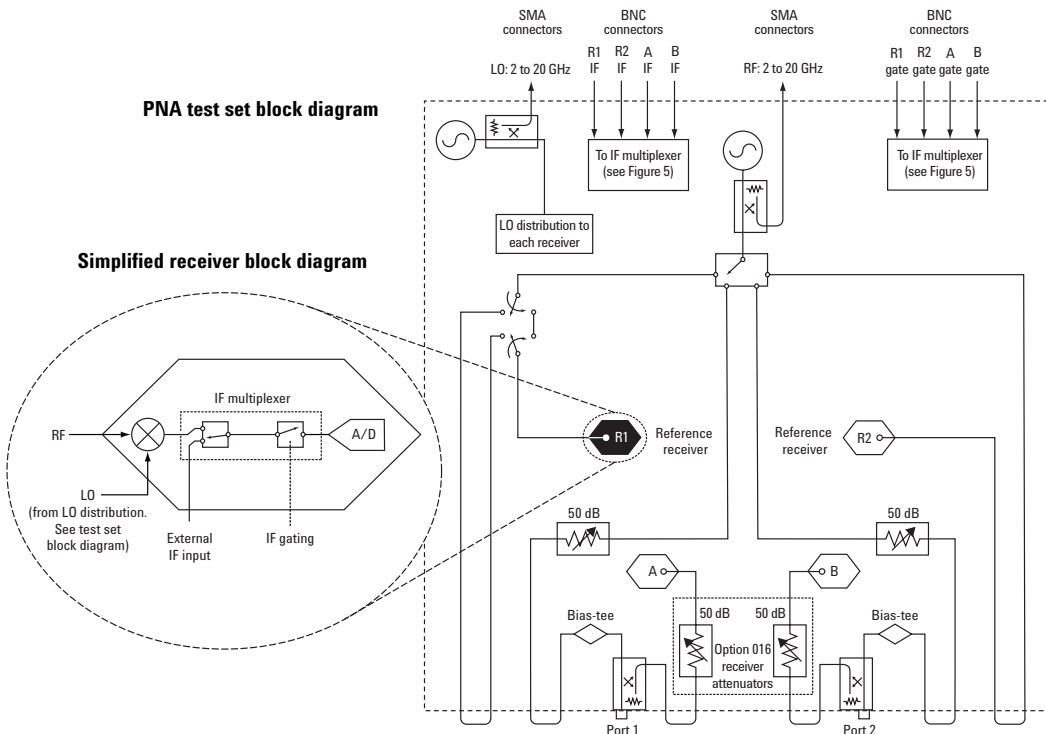



## Measurement Accessories

A complete list of RF and microwave test accessories is available on our Web site:

[www.agilent.com/find/accessories](http://www.agilent.com/find/accessories)

Accessories are available in these connector types: 50 ohm Type-N, 3.5 mm, 7 mm, 2.4 mm, 2.92 mm, 1.85 mm, 1.0 mm, and waveguide. Test port cables and a calibration kit should be added for a complete measurement system. A verification kit is used to verify corrected system performance.

### Cables and adapter sets

Agilent offers cables in the following types:

- single cables in semi-rigid and flexible
- cable sets in semi-rigid and flexible

There are also adapter sets available that protect the test port and convert the port to the desired connector interface. These kits contain:

- one male adapter
- one female adapter

To attain the best mechanical rigidity for device connection, use a single cable and the appropriate special adapter set. To attain the greatest flexibility for device connection, use a cable set.

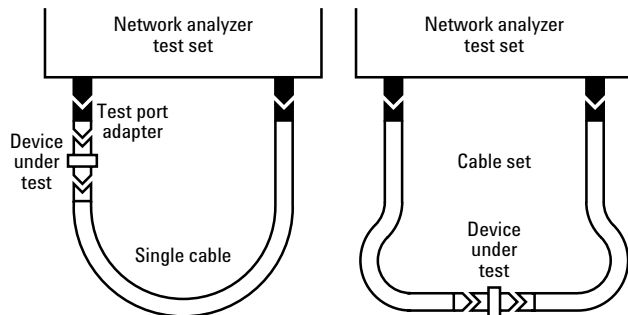

## Calibration kits

### Coaxial measurements

Mechanical calibration kits include standards, such as opens, shorts and loads, which are measured by the network analyzer for increased measurement accuracy.

Electronic calibration (ECal) kits replace mechanical calibration standards with one solid-state calibration module that is controlled by the network analyzer via USB, to present many different impedances to the test ports. A full two-port calibration can be performed quickly with a single connection. This technique reduces operator errors and connector wear and abrasion.

Choose a calibration kit for each connector type to be used.

**Economy**, includes:

- open standards (male and female)
- short standards (male and female)
- fixed-termination standards (male and female)

**Standard**, includes the devices in the economy kit and adds:

- sliding load standards (male and female) or a series of offset shorts

**Precision**, includes the devices in the economy kit and adds:

- 50 ohm airline(s) for TRL calibration
- TRL adapters

### Waveguide measurements

For waveguide measurements, Agilent offers mechanical calibration kits that include:

- waveguide-to-coax adapters (X, P, K, R, Q, U, V)
- precision waveguide section
- flush short circuit
- fixed terminations
- straight section

## For devices with 1.0 mm connectors

### **Mechanical calibration/verification kit**

- **85059A** DC to 110 GHz precision calibration/verification kit. Includes:
  - 85059-60003 1.00 mm (m) short 2.450 mm
  - 85059-60007 1.00 mm (f) short 2.450 mm
  - 85059-60004 1.00 mm (m) short 3.000 mm
  - 85059-60008 1.00 mm (f) short 3.000 mm
  - 85059-60002 1.00 mm (m) short 1.825 mm
  - 85059-60006 1.00 mm (f) short 1.825 mm
  - 85059-60001 1.00 mm (m) short 1.300 mm
  - 85059-60005 1.00 mm (f) short 1.300 mm
  - 85059-60009 1.00 mm male open
  - 85059-60010 1.00 mm female open
  - 85059-60019 1.00 mm male load
  - 85059-60020 1.00 mm female load
  - 85059-60021 1.00 mm lossy delay line
  - 11920-60001 1.00 mm (m) to 1.00 mm (m) adapter
  - 11920-60002 1.00 mm (f) to 1.00 mm (f) adapter
  - 11920-60003 1.00 mm (m) to 1.00 mm (f) adapter
  - 11500-60001 1.00 mm (f) to 1.00 mm (f) 8.8 cm cable
  - 85059-60016 1.00 mm mismatch thru adapter for verification
  - 85059-60017 1.00 mm matched thru adapter for verification
  - 8710-2079 6 mm, 4 in-lb torque wrench
  - 8710-2156 6 mm open end wrench

### **Cables**

- **11500I** 1.0 mm (f-f) test port cable (8.8 cm)
- **11500J** 1.0 mm (m-f) test port cable (16.0 cm)<sup>1</sup>
- **11500K** 1.0 mm (m-f) test port cable (20.0 cm)<sup>1</sup>
- **11500L** 1.0 mm (m-f) test port cable (24.0 cm)<sup>1</sup>

### **Adapter set**

- **V281C** 1.0 mm(f) to V-band waveguide adapter
- **V281D** 1.0 mm (m) to V-band waveguide adapter
- **W281C** 1.0 mm (f) to W-band waveguide adapter
- **W281D** 1.0 mm (m) to W-band waveguide adapter
- **11920A** 1.0 mm (m) to 1.0 mm (m) adapter
- **11920B** 1.0 mm (f) to 1.0 mm (f) adapter
- **11920C** 1.0 mm (m) to 1.0 mm (f) adapter
- **11921A** 1.0 mm (m) to 1.85 mm (m) adapter
- **11921B** 1.0 mm (f) to 1.85 mm (f) adapter
- **11921C** 1.0 mm (m) to 1.85 mm (f) adapter
- **11921D** 1.0 mm (f) to 1.85 mm (m) adapter
- **11922A** 1.0 mm (m) to 2.4 mm (m) adapter
- **11922B** 1.0 mm (f) to 2.4 mm (f) adapter
- **11922C** 1.0 mm (m) to 2.4 mm (f) adapter
- **11922D** 1.0 mm (f) to 2.4 mm (m) adapter
- **11923A** 1.0 mm (f) connector launch assembly

1. For on-wafer applications, two 11500J/K/L cables are required; one cable for each test port.

2. Special rugged female connector specifically for connecting to the network analyzer test port, but does not mate with a standard male connector.

## For devices with 1.85 mm connectors

### **Mechanical calibration kits**

- **85058B** standard: DC to 67 GHz. Includes:
  - 85058-60101 1.85 mm (m) short 5.4 mm
  - 85058-60102 1.85 mm (m) short 6.3 mm
  - 85058-60103 1.85 mm (m) short 7.12 mm
  - 85058-60104 1.85 mm (m) short 7.6 mm
  - 85058-60105 1.85 mm (f) short 5.4 mm
  - 85058-60106 1.85 mm (f) short 6.3 mm
  - 85058-60107 1.85 mm (f) short 7.12 mm
  - 85058-60108 1.85 mm (f) short 7.6 mm
  - 85058-60109 1.85 mm male open
  - 85058-60110 1.85 mm female open
  - 85058-60111 1.85 mm male load
  - 85058-60112 1.85 mm female load
  - 85058-60113 1.85 mm (m) to 1.85 mm (m) adapter
  - 85058-60114 1.85 mm (f) to 1.85 mm (f) adapter
  - 85058-60115 1.85 mm (m) to 1.85 mm (f) adapter
- **85058E** economy: DC to 67 GHz. Includes:
  - 85058-60101 1.85 mm (m) short 5.4 mm
  - 85058-60105 1.85 mm (f) short 5.4 mm
  - 85058-60109 1.85 mm male open
  - 85058-60110 1.85 mm female open
  - 85058-60123 1.85 mm male load
  - 85058-60124 1.85 mm female load
  - 85058-60113 1.85 mm (m) to 1.85 mm (m) adapter
  - 85058-60114 1.85 mm (f) to 1.85 mm (f) adapter
  - 85058-60115 1.85 mm (m) to 1.85 mm (f) adapter

### **Electronic calibration kits**

- **N4694A** Microwave ECal: 10 MHz to 67 GHz, 2 ports. Includes:
  - Option M0F** module with:
    - N4694-60001 1.85 mm (f) to 1.85 mm (m) ECal module
  - Option 00M** module with:
    - N4694-60002 1.85 mm (m) to 1.85 mm (m) ECal module
  - Option 00F** module with:
    - N4694-60003 1.85 mm (f) to 1.85 mm (f) ECal module
  - Option 00A** adds:
    - 85058-60113 1.85 mm (m) to 1.85 mm (m) adapter
    - 85058-60114 1.85 mm (f) to 1.85 mm (f) adapter

### **Cables<sup>2</sup>**

- **N4697E** Single, flexible: 1.85 mm (f) to 1.85 mm (f), 96.5 cm, 38 inches
- **N4697F** Set, flexible:
  - One 1.85 mm (f) to 1.85 mm (f) cable, 62.2 cm, 24.5 inches, p/n N4697-60100
  - One 1.85 mm (f) to 1.85 mm (m) cable, 62.2 cm, 24.5 inches, p/n N4697-60200

### **Adapter set**

- **85130H** 1.85 mm<sup>2</sup> to 1.85 mm

## For devices with 2.4 mm connectors

### Mechanical calibration kits

- **85056A** standard: DC to 50 GHz.

Includes:

- 00901-60003 2.4 mm (m) fixed broadband load
- 00902-60004 2.4 mm (f) fixed broadband load
- 00915-60003 2.4 mm (m) sliding load
- 00915-60004 2.4 mm (f) sliding load
- 85056-60005 2.4 mm (m) to 2.4 mm (m) adapter
- 85056-60006 2.4 mm (f) to 2.4 mm (f) adapter
- 85056-60007 2.4 mm (m) to 2.4 mm (f) adapter
- 85056-60020 2.4 mm (m) short
- 85056-60021 2.4 mm (f) short
- 85056-60022 2.4 mm (m) open
- 85056-60023 2.4 mm (f) open

- **85056D** economy: DC to 50 GHz.

Includes:

- 00901-60003 2.4 mm (m) fixed broadband load
- 00902-60004 2.4 mm (f) fixed broadband load
- 85056-60005 2.4 mm (m) to 2.4 mm (m) adapter
- 85056-60006 2.4 mm (f) to 2.4 mm (f) adapter
- 85056-60007 2.4 mm (m) to 2.4 mm (f) adapter
- 85056-60020 2.4 mm (m) short
- 85056-60021 2.4 mm (f) short
- 85056-60022 2.4 mm (m) open
- 85056-60023 2.4 mm (f) open

### Electronic calibration kits

- **N4693A** Microwave ECal: 10 MHz to 50 GHz, 2 ports.

Includes:

**Option M0F** module with:

- N4693-60001 2.4 mm (f) to 2.4 mm (m) ECal module

**Option 00M** module with:

- N4693-60002 2.4 mm (m) to 2.4 mm (m) ECal module

**Option 00F** module with:

- N4693-60003 2.4 mm (f) to 2.4 mm (f) ECal module

**Option 00A** adds:

- 85056-60005 2.4 mm (m) to 2.4 mm (m) adapter
- 85056-60007 2.4 mm (f) to 2.4 mm (f) adapter

### Cables<sup>1</sup>

- **85133C** single, semi-rigid: 2.4 mm (f) to PSC-2.4 mm (f), 81 cm, 32 inches
- **85133D** set, semi-rigid:
  - One 2.4 mm (f) to 2.4 mm (m), 53 cm, 21 inches, p/n 85133-60001
  - One 2.4 mm (f) to 2.4 mm (f), 53 cm, 21 inches, p/n 85133-60002
- **85133E** single, flexible: 2.4 mm (f) to PSC-2.4 mm (f), 97 cm, 38 inches
- **85133F** set, flexible:
  - One 2.4 mm (f) to 2.4 mm (f), 63 cm, 25 inches, p/n 85133-60016
  - One 2.4 mm (f) to 2.4 mm (m), 63 cm, 25 inches, p/n 85133-60017

### Adapter set

- **85130G** 2.4 mm<sup>1</sup> to 2.4 mm

## For devices with K connectors (2.92 mm)

### Mechanical calibration kits

- **85056K** 2.92/2.4 economy: DC to 40/50 GHz.

Includes:

- 00901-60003 2.4 mm (m) fixed broadband load
- 00902-60004 2.4 mm (f) fixed broadband load
- 00915-60003 2.4 mm (m) sliding load (Option 001)
- 00915-60004 2.4 mm (f) sliding load (Option 001)
- 11904-60001 2.4 mm (m) to 2.92 mm (m) adapter
- 11904-60002 2.4 mm (f) to 2.92 mm (f) adapter
- 11904-60003 2.4 mm (m) to 2.92 mm (f) adapter
- 11904-60004 2.4 mm (f) to 2.92 mm (m) adapter
- 85056-60005 2.4 mm (m) to 2.4 mm (m) adapter
- 85056-60006 2.4 mm (f) to 2.4 mm (f) adapter
- 85056-60007 2.4 mm (m) to 2.4 mm (f) adapter
- 85056-60020 2.4 mm (m) short
- 85056-60021 2.4 mm (f) short
- 85056-60022 2.4 mm (m) open
- 85056-60023 2.4 mm (f) open

### Electronic calibration kits

- **N4692A** Microwave ECal: 10 MHz to 40 GHz, 2 ports.

Includes:

**Option M0F** module with:

- N4692-60001 2.92 mm (f) to 2.92 mm (m) ECal module

**Option 00M** module with:

- N4692-60002 2.92 mm (m) to 2.92 mm (m) ECal module

**Option 00F** module with:

- N4692-60003 2.92 mm (f) to 2.92 mm (f) ECal module

**Option 00A** adds:

- N4692-60021 2.92 mm (m) to 2.92 mm (m) adapter
- N4692-60022 2.92 mm (f) to 2.92 mm (f) adapter

### Cables<sup>1</sup>

- **85133C** single, semi-rigid: 2.4 mm (f) to PSC-2.4 mm (f), 81 cm, 32 inches
- **85133D** set, semi-rigid:
  - One 2.4 mm (f) to 2.4 mm (m), 53 cm, 21 inches, p/n 85133-60001
  - One 2.4 mm (f) to 2.4 mm (f), 53 cm, 21 inches, p/n 85133-60002
- **85133E** single, flexible: 2.4 mm (f) to PSC-2.4 mm (f), 97 cm, 38 inches
- **85133F** set, flexible:
  - One 2.4 mm (f) to 2.4 mm (f), 63 cm, 25 inches, p/n 85133-60016
  - One 2.4 mm (f) to 2.4 mm (m), 63 cm, 25 inches, p/n 85133-60017

### Adapters

- **11904A** 2.4 mm (m) to K (m)
- **11904B** 2.4 mm (f) to K (f)
- **11904C** 2.4 mm (m) to K (f)
- **11904D** 2.4 mm (f) to K (m)
- **11904S** 2.4 mm to K adapter set

1. Special rugged female connector specifically for connecting to the network analyzer test port, but does not mate with a standard male connector.

## For devices with 3.5 mm or SMA connectors

### Mechanical calibration kits

- **85052B** standard: DC to 26.5 GHz. Includes:
  - 00902-60003 3.5 mm (m) fixed load
  - 00902-60004 3.5 mm (f) fixed load
  - 00911-60019 3.5 mm (m) sliding load
  - 00911-60020 3.5 mm (f) sliding load
  - 85052-60006 3.5 mm (m) short
  - 85052-60007 3.5 mm (f) short
  - 85052-60008 3.5 mm (m) open
  - 85052-60009 3.5 mm (f) open
  - 85052-60012 3.5 mm (f) to 3.5 mm (f) adapter
  - 85052-60013 3.5 mm (f) to 3.5 mm (m) adapter
  - 85052-60014 3.5 mm (m) to 3.5 mm (m) adapter
  
- **85052C** precision TRL: DC to 26.5 GHz. Includes:
  - 00902-60003 3.5 mm (m) fixed load
  - 00902-60004 3.5 mm (f) fixed load
  - 85052-60006 3.5 mm (m) short
  - 85052-60007 3.5 mm (f) short
  - 85052-60008 3.5 mm (m) open
  - 85052-60009 3.5 mm (f) open
  - 85052-60032 3.5 mm (f) to 3.5 mm (f) adapter
  - 85052-60033 3.5 mm (m) to 3.5 mm (m) adapter
  - 85052-60034 3.5 mm (f) to 3.5 mm (m) adapter
  - 85052-60035 3.5 mm short TRL line
  - 85052-60036 3.5 mm long TRL line
  
- **85052D** economy: DC to 26.5 GHz. Includes:
  - 00902-60003 3.5 mm (m) fixed load
  - 00902-60004 3.5 mm (f) fixed load
  - 85052-60006 3.5 mm (m) short
  - 85052-60007 3.5 mm (f) short
  - 85052-60008 3.5 mm (m) open
  - 85052-60009 3.5 mm (f) open
  - 85052-60012 3.5 mm (f) to 3.5 mm (f) adapter
  - 85052-60013 3.5 mm (f) to 3.5 mm (m) adapter
  - 85052-60014 3.5 mm (m) to 3.5 mm (m) adapter

### Electronic calibration kits

- **85093C** RF ECal: 300 kHz to 9 GHz, 2 ports
  - Standard module includes **Option M0F** with:
    - 85093-60008 3.5 mm (f) to 3.5 mm (m) ECal module
  - Option 00F** module with:
    - 85093-60010 3.5 mm (f) to 3.5 mm (f) ECal module
  - Option 00M** module with:
    - 85093-60009 3.5 mm (m) to 3.5 mm (m) ECal module
  - Option 00A** adds:
    - 85052-60012 3.5 mm (m) to 3.5 mm (m) adapter
    - 85052-60014 3.5 mm (f) to 3.5 mm (f) adapter

#### 85093C-xxx mixed-connector options:

Port A option			Port B option					
Type	(f)	(m)	Type	(f)	(m)	Type	(f)	(m)
3.5 mm	101	102	Type-N	203	204	7-16	205	206
			50 ohm					

- **N4431B** Microwave ECal: 300 kHz to 13.5 GHz, 4 ports.
  - Includes:
    - Option 010** module with:
      - N4431-60006 4 x 3.5 mm (f) ECal module

#### N4431B-xxx mixed-connector options:

Connector type	Port A option	Port B option	Port C option	Port D option
3.5 mm (f)	101	201	301	401
3.5 mm (m)	102	202	302	402
Type-N 50 ohm (f)	103	203	303	403
Type-N 50 ohm (m)	104	204	304	404
7-16 (f)	105	205	305	405
7-16 (m)	106	206	306	406

- **N4433A** Microwave ECal: 300 kHz to 20 GHz, 4 ports.
  - Includes:
    - Option 010** module with:
      - N4433-60003 4 x 3.5 mm (f) ECal module

#### N4433A-xxx mixed-connector options:

Connector type	Port A option	Port B option	Port C option	Port D option
3.5 mm (f)	101	201	301	401
3.5 mm (m)	102	202	302	402

- **N4691B** Microwave ECal: 300 kHz to 26.5 GHz, 2 ports.
  - Includes:
    - Option M0F** module with:
      - N4691-60001 3.5 mm (f) to 3.5 mm (m) ECal module
    - Option 00M** module with:
      - N4691-60002 3.5 mm (m) to 3.5 mm (m) ECal module
    - Option 00F** module with:
      - N4691-60003 3.5 mm (f) to 3.5 mm (f) ECal module
    - Option 00A** adds:
      - 85052-60012 3.5 mm (m) to 3.5 mm (m) adapter
      - 85052-60014 3.5 mm (f) to 3.5 mm (f) adapter

## **Cables<sup>1</sup>**

- **85131C** single, semi-rigid: 3.5 mm (f) to PSC-3.5 mm (f), 81 cm, 32 inches<sup>2</sup>
- **85131D** set, flexible:
  - One 3.5 mm (f) to 3.5 mm (m), 53 cm, 21 inches, p/n 85131-60009
  - One 3.5 mm (f) to PSC-3.5 mm (f), 53 cm, 21 inches, p/n 85131-60010
- **85131E** single, flexible: 3.5 mm (f) to PSC-3.5 mm (f), 96.5 cm, 38 inches<sup>2</sup>
- **85131F** set, flexible:
  - One 3.5 mm (f) to 3.5 mm (m), 62.2 cm, 24.5 inches, p/n 85131-60012
  - One 3.5 mm (f) to PSC-3.5 mm (f), 62.2 cm, 24.5 inches, p/n 85131-60013
- **85134C** single, semi-rigid: PSC-3.5 mm (f) to 2.4 mm (f), 81 cm, 32 inches
- **85134D** set, semi-rigid:
  - One 2.4 mm (f) to PSC-3.5 mm (f), 53 cm, 21 inches, p/n 85134-60002
  - One 2.4 mm (f) to PSC-3.5 mm (m), 53 cm, 21 inches, p/n 85134-60001
- **85134E** single, flexible: PSC-3.5 mm (f) to 2.4 mm (f), 96 cm, 38 inches
- **85134F** set, flexible:
  - One 2.4 mm (f) to PSC-3.5 mm (f), 53 cm, 21 inches, p/n 85134-60004
  - One 2.4 mm (f) to PSC-3.5 mm (m), 53 cm, 21 inches, p/n 85134-60003
- **N4419A-B20** set, flexible: 3.5 mm (m) to 3.5 mm (f), 4 cables, 36 inches each, purple colored cables
- **Z5623A-B20** set, flexible: 3.5 mm (m) to 3.5 mm (m), 4 cables, 36 inches each, purple colored cables

## **Adapter sets**

- **85130C** 3.5 mm<sup>1</sup> to Type-N
- **85130D** 3.5 mm<sup>1</sup> to 3.5 mm
- **85130F** 2.4 mm<sup>1</sup> to 3.5 mm

---

1. Special rugged female connector specifically for connecting to the network analyzer test port, but does not mate with a standard male connector.

2. For use with E8362A or B.

## For devices with Type-N connectors

### Mechanical calibration kits

- **85054B** standard: DC to 18 GHz. Includes:
  - 00909-60011 Type-N (m) fixed lowband load
  - 00909-60012 Type-N (f) fixed lowband load
  - 85054-60025 Type-N (m) short
  - 85054-60026 Type-N (f) short
  - 85054-60027 Type-N (m) open
  - 85054-60028 Type-N (f) open
  - 85054-60031 Type-N (f) to 7mm adapter
  - 85054-60032 Type-N (m) to 7mm adapter
  - 85054-60037 Type-N (f) to Type-N (f) adapter
  - 85054-60038 Type-N (m) to Type-N (m) adapter
  - 85054-80010 Type-N (f) sliding load
  - 85054-80009 Type-N (m) sliding load
  - 85054-60050 Type-N (f) connector gage
  - 85054-60052 Type-N (f) gage master
  - 85054-60051 Type-N (m) connector gage
  - 85054-60053 Type-N (m) gage master
- **85054D** economy: DC to 18 GHz. Includes:
  - 85054-60025 Type-N (m) short
  - 85054-60026 Type-N (f) short
  - 85054-60027 Type-N (m) open
  - 85054-60028 Type-N (f) open
  - 85054-60031 Type-N (f) to 7mm adapter
  - 85054-60032 Type-N (m) to 7mm adapter
  - 85054-60037 Type-N (f) to Type-N (f) adapter
  - 85054-60038 Type-N (m) to Type-N (m) adapter
  - 85054-60046 Type-N (m) fixed load
  - 85054-60047 Type-N (f) fixed load

### Electronic calibration kits

- **N4431B** Microwave ECal: 300 kHz to 13.5 GHz, 4 ports.  
Includes:  
**Option 020** module with:  
N4431-60007 4 x Type-N (f) ECal module

#### N4431B-xxx mixed-connector options:

Connector type	Port A option	Port B option	Port C option	Port D option
3.5 mm (f)	101	201	301	401
3.5 mm (m)	102	202	302	402
Type-N 50 ohm (f)	103	203	303	403
Type-N 50 ohm (m)	104	204	304	404
7-16 (f) <sup>1</sup>	105	205	305	405
7-16 (m) <sup>1</sup>	106	206	306	406

- **N4432A** Microwave ECal: 300 kHz to 18 GHz, 4 ports.  
Includes:  
**Option 020** module with:  
N4432-60003 4 x Type-N (50-ohm) (f) ECal module

#### N4432A-xxx mixed-connector options:

Connector type	Port A option	Port B option	Port C option	Port D option
3.5 mm (f)	101	201	301	401
3.5 mm (m)	102	202	302	402
Type-N 50 ohm (f)	103	203	303	403
Type-N 50 ohm (m)	104	204	304	404

- **N4690B** Microwave ECal: 300 kHz to 18 GHz, 2 ports.  
Includes:  
**Option M0F** module with:  
N4690-60001 Type-N (f) to Type-N (m) ECal module  
**Option 00M** module with:  
N4690-60002 Type-N (m) to Type-N (m) ECal module  
**Option 00F** module with:  
N4690-60003 Type-N (f) to Type-N (f) ECal module  
**Option 00A** adds:  
85054-60037 Type-N (f) to Type-N (f) adapter  
85054-60038 Type-N (m) to Type-N (m) adapter

### Cables<sup>2</sup>

Use the test port cables recommended for devices with 7 mm connectors, and 7 mm to Type-N adapters that are from the 85054B/D Type-N calibration kit (see 7 mm connector section).

1. Limits ECal module high frequency to 7.5 GHz.  
2. Special rugged female connector specifically for connecting to the network analyzer test port, but does not mate with a standard male connector.



## For devices with 7 mm connectors

### **Mechanical calibration kits**

- **85050B** standard: DC to 18 GHz. Includes:
  - 00909-60008 7 mm coax termination
  - 85050-60006 7 mm fixed broadband load
  - 85050-80007 7 mm short
  - 85050-80010 7 mm open
  - 85050-80011 7 mm sliding load
- **85050C** precision TRL: DC to 18 GHz. Includes:
  - 00909-60008 7 mm coax termination
  - 85050-60003 7 mm to 7 mm airline
  - 85050-60005 7 mm to 7 mm TRL adapter
  - 85050-60006 7 mm fixed broadband load
  - 85050-80008 7 mm short
  - 85050-80009 7 mm short collet
  - 85050-80010 7 mm open
- **85050D** economy: DC to 18 GHz. Includes:
  - 85050-60006 7 mm fixed broadband load
  - 85050-80007 7 mm short
  - 85050-80010 7 mm open

### **Electronic calibration kits**

- **N4696B** Microwave ECal: 300 kHz to 18 GHz, 2 ports, 7mm to 7mm Microwave module

### **Cables<sup>1</sup>**

- **85132C** single, semi-rigid: 7 mm to 3.5 mm (f), 81 cm, 32 inches<sup>2</sup>
- **85132D** set, semi-rigid: two 3.5 mm (f) to 7 mm cables, 53 cm each, 21 inches each<sup>2</sup>, p/n 85132-60003
- **85132E** single, flexible: 7 mm to 3.5 mm (f), 97.2 cm, 38.25 inches<sup>2</sup>
- **85132F** set, flexible: two 3.5 mm (f) to 7 mm cables, 62.9 cm each, 24.75 inches each<sup>2</sup>, p/n 85132-60004
- **85135C** single, semi-rigid: 7 mm to 2.4 mm (f), 81 cm, 32 inches
- **85135D** set, semi-rigid: two 2.4 mm (f) to 7 mm cables, 53 cm each, 21 inches each, p/n 85135-60001
- **85135E** single, flexible: 7 mm to 2.4 mm (f), 96 cm, 38 inches
- **85135F** set, flexible: two 2.4 mm (f) to 7 mm cables, 53 cm each, 21 inches each, p/n 85135-60002

### **Adapter sets**

- **85130E** 2.4 mm<sup>1</sup> to 7 mm

## For devices with waveguide

### **Mechanical calibration kits**

#### **X Band**

- **X11644A** standard, WR-90: 8.2 to 12.4 GHz. Includes:
  - 00896-60008 X-band standard section
  - 00910-60003 X-band termination
  - 11644-20018 X-band short
  - 11644-20021 X-band shim
- **85132F** cable set (set, flexible 7 mm to 3.5 mm, 62.9 cm each, 24.75 inches each<sup>2</sup>)
- **85135F** cable set (set, flexible, 7 mm to 2.4 mm, 53 cm each, 21 inches each)
- **X281C** adapter (included in calibration kit): WR-90 to 7 mm

#### **P Band**

- **P11644A** standard, WR-62: 12.4 to 18 GHz. Includes:
  - 00896-60007 P-band standard section
  - 00910-60002 P-band termination
  - 11644-20017 P-band short
  - 11644-20020 P-band shim
- **85132F** cable set (set, flexible 7 mm to 3.5 mm, 62.9 cm each, 24.75 inches each<sup>2</sup>)
- **85135F** cable set (flexible, 7 mm to 2.4 mm, 53 cm each, 21 inches each)
- **P281C** adapter (included in calibration kit): WR-62 to 7 mm

#### **K Band**

- **K11644A** standard, WR-42: 18 to 26.5 GHz. Includes:
  - 00896-60006 K-band standard section
  - 00910-60001 K-band termination
  - 11644-20016 K-band short
  - 11644-20019 K-band shim
- **85134F** cable set (set, flexible, 3.5 mm to 2.4 mm, 53 cm each, 21 inches each)
- **K281C** adapter (included in calibration kit): WR-42 to 3.5 mm (f)  
**Option 012** WR-42 to 3.5 mm (m)

1. Special rugged female connector specifically for connecting to the network analyzer test port, but does not mate with a standard male connector.

2. For use with E8362A or B.



## R Band

- **R11644A** standard, WR-28: 26.5 to 40 GHz.  
Includes:
  - 00914-20028 R-band termination
  - 11644-20005 R-band short
  - 11644-20003 R-band shim
  - 11644-60001 R-band 10 cm straight waveguide
  - 11644-60016 R-band 5 cm straight waveguide
- **85133F** cable set (set, flexible, 2.4 mm, 53 cm each, 21 inches each)
- **R281A** adapter (2.4 mm (f) to WR-28 waveguide adapter)
- **R281B** adapter (2.4 mm (m) to WR-28 waveguide adapter)

## Q Band

- **Q11644A** standard, WR-22: 33 to 50 GHz.  
Includes:
  - 11644-60005 Q-band termination
  - 11644-20004 Q-band short
  - 11644-20001 Q-band shim
  - 11644-60002 Q-band 10 cm straight waveguide
  - 11644-60017 Q-band 5 cm straight waveguide
- **85133F** cable set (set, flexible, 2.4 mm, 53 cm each, 21 inches each)
- **Q281A** adapter (2.4 mm (f) to WR-22 waveguide adapter)
- **Q281B** adapter (2.4 mm (m) to WR-22 waveguide adapter)

## U Band

- **U11644A** standard, WR-19: 40 to 60 GHz.  
Includes:
  - 11644-60006 U-band termination
  - 11644-20004 U-band short
  - 11644-20002 U-band shim
  - 11644-60003 U-band 10 cm straight waveguide
  - 11644-60018 U-band 5 cm straight waveguide

## V Band

- **V11644A** standard, WR-15: 50 to 75 GHz.  
Includes:
  - 11644-60025 V-band termination
  - 11644-20015 V-band short
  - 11644-20013 V-band shim
  - 11644-60012 V-band standard section

## Verification kits

All Agilent verification kits include:

- precision Zo airline or match thru
  - mismatched airline or mismatch thru
  - fixed attenuators
  - traceable measured data and uncertainties
- **85053B** 300 kHz to 26.5 GHz 3.5 mm kit  
Includes attenuators, airline and mismatch airline with data on a 3.5-inch disk for use in confirming accuracy enhanced system measurement performance, traceable to national standards. Test procedure is provided in the service manual.
  - **85055A** 300 kHz to 18 GHz Type-N kit  
Includes attenuators, airline and mismatch airline with data on a 3.5-inch disk for use in confirming accuracy enhanced system measurement performance, traceable to national standards. Test procedure is provided in the service manual.
  - **85057B** 45 MHz to 50 GHz 2.4 mm kit  
Includes attenuators, airline and mismatch airline with data on a 3.5-inch disk for use in confirming accuracy enhanced system measurement performance, traceable to national standards. Test procedure is provided in the service manual.
  - **85058V** 45 MHz to 67 GHz 1.85 mm kit  
Includes attenuators, match thru and mismatch thru with data on a 3.5-inch disk for use in confirming accuracy enhanced system measurement performance, traceable to national standards. Test procedure is provided in the service manual.

# General Accessories

## USB

- N4688A** CD-ROM drive  
Provides an external read/write CD-ROM drive with a USB cable.
- N4689A** USB hub  
Provides a USB hub for connecting additional USB peripherals.

## Hard drive

- N8980A** Spare hard drive  
Recommended for a secure environment.

## Probe

- 85024A** high-frequency probe  
Provides high-impedance in-circuit test capability from 300 kHz to 3 GHz.

## Power meters and sensors<sup>1</sup>

Recommended for self support, adjustments and performance tests to verify proper instrument operation.

- E4418B** single-channel power meter
- E4419B** dual-channel power meter
- 8481B** power sensor, 10 MHz to 18 GHz, Type-N (m), 25 W
- 8481A** power sensor, 10 MHz to 18 GHz, Type-N (m), 100 mW
- 8485A** power sensor, 50 MHz to 26.5 GHz, APC-3.5 mm (m), 100 mW
- 8487A** power sensor, 50 MHz to 50 GHz, 2.4 mm, 300 mW
- 8487D** power sensor, 50 MHz to 50 GHz, 2.4 mm, 100 mW
- R8486A** power sensor, 26 GHz to 40 GHz, waveguide flange UG-599/U, 100 mW
- Q8486A** power sensor, 33 GHz to 50 GHz, waveguide flange UG-383/U, 100 mW
- U8486A** power sensor, 50 GHz to 75 GHz, waveguide flange UG-385/U, 200 mW avg
- E4412A** CW power sensor, 10 MHz to 18 GHz, Type-N (m), 200 mW
- E4413A** CW power sensor, 50 MHz to 265 GHz, 3.5 mm, 200 mW

## Amplifiers

- 83006A** power amplifier, 10 MHz to 26.5 GHz, 20 dB gain, power out: +18 dBm to 10 GHz or +16 dBm to 20 GHz or +14 dBm to 26.5 GHz
- 83017A** power amplifier, 50 MHz to 26.5 GHz, 25 dB gain, power out: +20 dBm to 20 GHz, or +15 dBm to 26.5 GHz
- 83018A** power amplifier, 2 to 26.5 GHz, 27 dB gain to 20 GHz or 23 dB to 26.5 GHz, power out: +24 dBm to 20 GHz or +21 dBm to 26.5 GHz
- 83020A** power amplifier, 2 to 26.5 GHz, 30 dB gain to 20 GHz or 27 dB to 26.5 GHz, power out: +30 dBm to 20 GHz or +26 dBm to 26.5 GHz
- 83050A** power amplifier, 2 to 50 GHz, 23 dB gain, power out: +20 dBm to 40 GHz or +17 dBm to 50 GHz
- 83051A** power amplifier, 45 MHz to 50 GHz, 23 dB gain power out: +12 dBm to 45 GHz or +10 dBm to 50 GHz

## Couplers

- 87300B** coaxial coupler, 1 to 20 GHz, SMA (f), 10 dB coupling
- 87300C** coaxial coupler, 1 to 26.5 GHz, 3.5 mm (f), 10 dB coupling
- 87301B** coaxial coupler, 10 to 46 GHz, 2.9 mm (f), 10 dB coupling
- 87301D** coaxial coupler, 1 to 40 GHz, 2.4 mm (f) or optional 2.92 mm (f), 13 dB coupling
- 87301E** coaxial coupler, 2 to 50 GHz, 2.4 mm (f), 10 dB coupling
- 87310B** 90° coaxial coupler, 1 to 18 GHz, SMA (f), 3 dB coupling

## Equipment rack accessories

- E3663AC** Rail kit
- 5063-9205** Front handle kit
- 5063-9217** Rack mount kit, for use without handles (included with Option 1CM)
- 5063-9224** Rack mount kit with handles
- 5063-9237** Rack mount kit, for use with standard supplied handles (included with Option 1CP)

---

1. For the latest guide to power meters and power sensors, refer to the Agilent web site: [www.agilent.com/find/powermeters](http://www.agilent.com/find/powermeters)

# Applications

## Material measurements

- **85070E** High-Temperature Dielectric Probe Kit  
The 85070E enables measurements of the dielectric properties of materials quickly and conveniently. Measurements made with this probe are nondestructive and require no sample preparation. The dielectric probe is well suited for measurements of liquid, semisolid and flat solid materials. Measurement results can be viewed in a variety of formats ( $\epsilon'_r$ ,  $\epsilon''_r$ ,  $\tan \delta$  or Cole-Cole). The supplied software can be run in the PNA analyzer or on a PC.
- **85071E** Materials Measurement Software  
The 85071E materials measurement software calculates the permittivity and permeability of material samples placed in a coaxial airline or a rectangular waveguide. The measurement technique works well for solid materials that can be machined to fit precisely inside a transmission line. Measurement results can be viewed in a variety of formats ( $\epsilon'_r$ ,  $\epsilon''_r$ ,  $\mu'_r$ ,  $\mu''_r$ ,  $\tan \delta$ , or Cole-Cole  $\mu$ ). The software can be run in the PNA analyzer or on a PC.

## Pulsed measurements<sup>1</sup>

The pulsed RF measurement capability (Option H08) and IF access (Option H11), are recommended for pulsed measurements with the PNA Series.

### **Pulse/pattern generators**

Recommended to provide pulse signals and timing to the pulsed S-parameter text set and MW PNA

- **81110A** Pulse/pattern generator, 165 MHz single-/dual-channel with one or two Agilent 81111A output modules  
*Note: The 81110A must be ordered with the associated output modules depending on the measurement configuration.*

### **Pulsed S-Parameter test sets**

- **Z5623AH81** Pulsed S-parameter test set, 2 to 20 GHz  
Includes a pin-diode switch to modulate the analyzer's internal source, an amplifier, and directional coupler to provide a pulsed reference to the analyzer.  
*Note: Pulse biasing can be achieved with or without the use of a pulsed S-parameter test set. A proper pulse-bias driver must be used. Contact your local Agilent Sales Representative for additional pulsed S-parameter test set configurations and details.*

# Peripherals

The following peripherals may be used with the Microwave PNA Series. Other peripherals not listed here may also be compatible with these instruments.

## Monitors

VGA-compatible monitor

## Printers

USB, LAN, parallel or serial printers with Microsoft® Windows® printer driver

## Interface cables

Choose the appropriate cables to connect each peripheral to the network analyzer.

- **10833A** GPIB cable, 1.0 m (3.3 ft)
- **10833B** GPIB cable, 2.0 m (6.6 ft)
- **10833D** GPIB cable, 0.5 m (1.6 ft)
- **82357A** GPIB to USB interface

1. For more details regarding pulsed measurement configurations with the PNA Series, refer to Agilent's Web site ([www.agilent.com/find/pna](http://www.agilent.com/find/pna)) to download a copy of the *Microwave PNA Series Network Analyzer Configuration Guide for Pulsed Measurements*, literature number 5988-9833EN.

# Upgrade Kits

## Upgrade kits for the PNA Series E8362A, E8363A, E8364A, E8362B, E8363B, E8364B, E8361A, N5250A

Upgrade kits are available to add options after initial purchase. To order an upgrade kit for the PNA series, order the analyzer's model number followed by a "U", then indicate the option to be added (for example, E8362BU-010). The serial number of the instrument to be retrofitted is required as part of the order.

- Time-domain** (Option 010)  
User installable.
- Configurable test set** (Option 014)  
Provides six front-panel RF access loops.  
Includes installation at an Agilent service center.
- Receiver attenuators** (Option 016)  
(Not available for the E8362A/63A/64A)  
Includes installation at an Agilent service center.
- Extended memory** (Option 022)  
(Not available for the E8362A/63A/64A)  
Includes installation at an Agilent service center.
- Frequency range upgrade to an E8363A/B (40 GHz) PNA** (Option 040)  
Available only for the E8362A/B. Includes installation at an Agilent service center.
- Frequency range upgrade to an E8364A/B (50 GHz) PNA** (Option 050)  
Available only for the E8362A/B and E8363A/B.  
Includes installation at an Agilent service center.
- Frequency range upgrade to an E8361A (67 GHz) PNA** (Option 067)  
Available only for the E8363A/B and E8364A/B.  
Includes installation at an Agilent service center.
- Frequency-offset** (Option 080)  
(Not available for the E8362A/63A/64A)  
Includes installation at an Agilent service center.
- External reference switch** (Option 081)  
(Not available for the E8362A/63A/64A)  
Includes installation at an Agilent service center.
- Frequency converter measurement application** (Option 083)  
(Not available for the E8362A/63A/64A)  
User installable.
- Extended hardware capability** (Option 097)  
(Available for the E8362A/63A/64A only)  
This option will upgrade your E836xA model to an E836xB model; adding a 10 MHz start frequency and the ability to add the options needed to test mixers (080, 081, and 083).
- 4-Port measurement application** (Option 550)  
(Available for E8361A, E8362/3/4B, N5230A)  
Enables full 4-port error correction and differential measurements. External test set required. User installable.
- Extended power range** (Option UNL)  
Adds a step attenuator and a bias-tee between source and each test port. Includes installation at an Agilent service center.
- Pulsed-RF measurement capability** (Option H08)  
Provides software to set up and control pulsed-RF measurements using narrowband detection, with point-in-pulse and pulse-profile capability. User installable.
- IF access** (Option H11)  
Provides hardware for antenna, point-in-pulse, and millimeter-wave measurements. Adds rear-panel RF and LO outputs, external IF inputs, and IF gates (gates enabled with Option H08). Includes installation at an Agilent service center.

## Upgrade kits for the PNA-L Series N5230A

Upgrade kits are available to add options after initial purchase. To order an upgrade kit for the PNA-L series, order the analyzer's model number followed by a "U", then indicate the option to be added (example: N5230AU-010). The serial number of the instrument to be retrofitted is required as part of the order.

**Time-domain upgrade kit** (Option 010)

The serial number of the instrument to be retrofitted must be specified when ordering this kit. User installable.

**4-port measurement application** (Option 550)

Enables full, 4-port error correction and differential measurements on a 2-port network analyzer. External test set required. User installable.

**6 or 13.5 GHz configurable test set & extended power range upgrade kit** (Option 901)

Applicable to 6 or 13.5 GHz PNA-L (N52300-020, N52300-120). Upgrade to configurable test set and extended power range. Includes installation at an Agilent service center.

**20 GHz 2-port configurable test set & extended power range upgrade kit** (Option 921)

Applicable to 20 GHz PNA-L (N52300-220). Upgrade to configurable test set and extended power range. Includes installation at an Agilent service center.

**20 GHz 4-port configurable test set & extended power range upgrade kit** (Option 926)

Applicable to 20 GHz 4-port PNA-L (N52300-240). Upgrade to configurable test set and extended power range. Includes installation at an Agilent service center.

**40 or 50 GHz configurable test set & extended power range upgrade kit** (Option 941)

Applicable to 40 or 50 GHz PNA-L (N52300-420, N52300-520). Upgrade to configurable test set and extended power range. Includes installation at an Agilent service center.

**Frequency-offset upgrade kit** (Option 080)

The serial number of the instrument to be retrofitted must be specified when ordering this kit. User installable.

**Frequency range upgrade from 6 to 13.5 GHz** (Option 960)

Applicable to the 6 GHz PNA-L (N52300-020, N52300-025). Includes installation at an Agilent service center.

**Frequency range upgrade from 20 to 40 GHz** (Option 971)

Applicable to the 20 GHz PNA-L (N52300-220). Includes installation at an Agilent service center.

**Frequency range upgrade from 20 to 40 GHz** (Option 973)

Applicable to the 20 GHz PNA-L (N52300-225). Includes installation at an Agilent service center.

**Frequency range upgrade from 40 to 50 GHz** (Option 990)

Applicable to the 40 GHz PNA-L (N52300-420, N52300-425). Includes installation at an Agilent service center.

For additional upgrade paths, contact your Agilent field office.

# Key Web Resources

Visit our Web sites for additional product information and literature:

[www.agilent.com/find/pna](http://www.agilent.com/find/pna)

Electronic calibration (ECal) visit:

[www.agilent.com/find/ecal](http://www.agilent.com/find/ecal)

Material test equipment:

[www.agilent.com/find/materials](http://www.agilent.com/find/materials)

Test and measurement accessories:

[www.agilent.com/find/accessories](http://www.agilent.com/find/accessories)

Antenna and radar cross-section products visit:

[www.agilent.com/find/antenna](http://www.agilent.com/find/antenna)

Multiport test sets visit:

[www.agilent.com/find/multiport](http://www.agilent.com/find/multiport)

Pulsed-RF products visit:

[www.agilent.com/find/pulsedRF](http://www.agilent.com/find/pulsedRF)

Mixer, converter, and tuner products visit:

[www.agilent.com/find/mixers](http://www.agilent.com/find/mixers)

On-wafer and in-fixture measuring products visit:

[www.agilent.com/find/probingRF](http://www.agilent.com/find/probingRF)

Agilent's service and support products visit:

[www.agilent.com/find/tm\\_services](http://www.agilent.com/find/tm_services)

## Expand your measurement capabilities with Agilent qualified channel partners

Our channel partners offer accessories and measurement solutions that extend your network analysis capabilities.

For more information about probing equipment and accessories, contact:

### Cascade Microtech, Inc

2430 NW 206th Avenue

Beaverton, Oregon 97006, USA

Toll free telephone: 1-800-550-3279

Telephone: (503) 601-1000

Fax: (503) 601-1002

Web site: [www.cascademicrotech.com](http://www.cascademicrotech.com)

E-mail: [sales@cmicro.com](mailto:sales@cmicro.com)



### Agilent Email Updates

[www.agilent.com/find/emailupdates](http://www.agilent.com/find/emailupdates)

Get the latest information on the products and applications you select.



### Agilent Direct

[www.agilent.com/find/agilentdirect](http://www.agilent.com/find/agilentdirect)

Quickly choose and use your test equipment solutions with confidence.

Microsoft® and Windows® are U.S. registered trademarks of Microsoft Corporation.

## www.agilent.com

### Agilent Technologies' Test and Measurement Support, Services, and Assistance

Agilent Technologies aims to maximize the value you receive, while minimizing your risk and problems. We strive to ensure that you get the test and measurement capabilities you paid for and obtain the support you need. Our extensive support resources and services can help you choose the right Agilent products for your applications and apply them successfully. Every instrument and system we sell has a global warranty. Two concepts underlie Agilent's overall support policy: "Our Promise" and "Your Advantage."

#### Our Promise

Our Promise means your Agilent test and measurement equipment will meet its advertised performance and functionality. When you are choosing new equipment, we will help you with product information, including realistic performance specifications and practical recommendations from experienced test engineers. When you receive your new Agilent equipment, we can help verify that it works properly and help with initial product operation.

#### Your Advantage

Your Advantage means that Agilent offers a wide range of additional expert test and measurement services, which you can purchase according to your unique technical and business needs. Solve problems efficiently and gain a competitive edge by contracting with us for calibration, extra-cost upgrades, out-of-warranty repairs, and onsite education and training, as well as design, system integration, project management, and other professional engineering services. Experienced Agilent engineers and technicians worldwide can help you maximize your productivity, optimize the return on investment of your Agilent instruments and systems, and obtain dependable measurement accuracy for the life of those products.

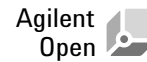

### [www.agilent.com/find/open](http://www.agilent.com/find/open)

Agilent Open simplifies the process of connecting and programming test systems to help engineers design, validate and manufacture electronic products. Agilent offers open connectivity for a broad range of system-ready instruments, open industry software, PC-standard I/O and global support, which are combined to more easily integrate test system development.

#### United States:

(tel) 800 829 4444

(fax) 800 829 4433

#### Canada:

(tel) 877 894 4414

(fax) 800 746 4866

#### China:

(tel) 800 810 0189

(fax) 800 820 2816

#### Europe:

(tel) 31 20 547 2111

#### Japan:

(tel) (81) 426 56 7832

(fax) (81) 426 56 7840

#### Korea:

(tel) (080) 769 0800

(fax) (080) 769 0900

#### Latin America:

(tel) (305) 269 7500

#### Taiwan:

(tel) 0800 047 866

(fax) 0800 286 331

#### Other Asia Pacific

##### Countries:

(tel) (65) 6375 8100

(fax) (65) 6755 0042

Email: [tm\\_ap@agilent.com](mailto:tm_ap@agilent.com)

Contacts revised: 09/26/05

For more information on Agilent Technologies' products, applications or services, please contact your local Agilent office. The complete list is available at:

### [www.agilent.com/find/contactus](http://www.agilent.com/find/contactus)

Product specifications and descriptions in this document subject to change without notice.

© Agilent Technologies, Inc. 2002, 2003, 2004, 2005, 2006

Printed in USA, April 25, 2006

5988-7989EN



Agilent Technologies