

Rotary Vane Attenuators

Series 110 - The Industry Standard

For Programmable Vane Rotary Attenuators see page 6-9

Features

- **1% accuracy**
- **0 - 60 dB**
- **Direct Reading**
- **Unsurpassed Reliability**

Flann Precision Rotary Vane Attenuators are considered by many to represent the 'Industry Standard' in precision waveguide attenuators, offering high accuracy and unsurpassed repeatability and reliability.

The Rotary Vane Attenuator is the ideal instrument for use in waveguide systems where broadband direct reading of attenuation is required, particularly as a standard for reflectometer and swept systems.

The Flann Rotary Vane Attenuator consists of a rotating circular waveguide section flanked by a pair of low VSWR rectangular to circular transitions. The three waveguide sections are fitted with stable high attenuation elements which ensure close agreement of the attenuation characteristic to the theoretical law. The attenuation is directly related to the relative

angular position of the attenuating element in the centre section (θ) and can be seen to follow the law $40 \log (\sec \theta)$. The attenuation is insensitive to frequency; variations of phase with attenuation are negligible. Choking of the rotating joints is employed to minimise RF leakage whilst sound mechanical design ensures the instruments are free from backlash. A precision 10 turn, 75 mm diameter helical drum scale provides extremely high resolution as the table below indicates:-

Attenuation scale range	1-4dB	4-30dB	30-40dB	40-60dB
Scale increment	0.01dB	0.1dB	0.2dB	0.5dB

Discrimination of the drum scale over a 0 to 60 dB attenuation range

By using high value attenuation markings on the scale, symmetrically positioned about the maximum attenuation position, the user is able to verify the attenuation characteristic alignment which gives the highest confidence in the accuracy of subsequent measurements.

Custom Built Units:-

Special attenuators can be supplied with a calibration range in excess of 60 dB. Combined rotary vane attenuator and rotary vane phase changer units are also available; these units are usually coupled at the circular waveguide section thereby minimising mismatch errors at low attenuation settings.



Model 24110

ORDERING INFORMATION

Model: Description
Example: Model 16110 Rotary Vane Attenuator

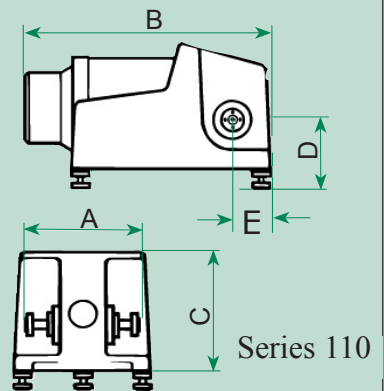

Specifications

Attenuation Range 0 to 60 dB
Attenuation accuracy 0.1 or 1% of reading, whichever is the greater
 (except Model 06110 - 0.2 dB or 2%, whichever is the greater)

Model	Frequency Range (GHz)	Waveguide			Maximum VSWR	Maximum Insertion Loss (dB)	Maximum Power (watts)	Dimensions (mm)					Weight (kg)	Model
		WG	R	WR				A	B	C	D	E		
10110	2.60 - 2.61	10	32	284	1.15	0.5	12	935	358	198	88.2*	108	28	10110
11A110	3.30 - 4.90	11A	40	229	1.15	0.5	10	687	340	156	81.2*	85	13	11A110
12110	3.94 - 5.99	12	48	187	1.15	0.5	10	560	244	149	66/75	58	8.5	12110
13110	4.64 - 7.05	13	58	159	1.15	0.5	9	520	244	149	66/75	58	8.0	13110
14110	5.38 - 8.18	14	70	137	1.15	0.5	8	420	244	149	66/75	58	6.0	14110
15110	6.58 - 10.0	15	84	112	1.15	0.5	6	340	226	119	45/54	44	4.0	15110
16110	8.20 - 12.5	16	100	90	1.15	0.5	4	300	226	119	45/54	44	3.8	16110
17110	9.84 - 15.0	17	120	75	1.15	0.5	3	276	226	119	45/54	44	3.8	17110
18110	11.9 - 18.0	18	140	62	1.15	0.5	2	250	226	119	45/54	44	3.4	18110
19110	14.5 - 22.0	19	180	51	1.15	0.5	2	250	226	119	45/54	44	3.4	19110
20110	17.6 - 26.7	20	220	42	1.15	0.8	1	250	226	119	45/54	44	3.3	20110
21110	21.7 - 33.0	21	260	34	1.15	0.8	1	225	226	119	45/54	44	3.2	21110
22110	26.4 - 40.1	22	320	28	1.15	1.0	0.7	174	227	119	55/64	36	2.5	22110
23110	33.0 - 50.1	23	400	22	1.15	1.0	0.7	140	227	119	55/64	36	2.5	23110
24110	39.3 - 59.7	24	500	19	1.15	1.0	0.7	134	227	119	55/64	36	2.3	24110
25110	49.9 - 75.8	25	620	15	1.15	1.0	0.5	100	227	119	55/64	36	2.3	25110
26110	60.5 - 92.0	26	740	12	1.15	1.5	0.3	89	227	119	55/64	36	2.3	26110
27110	73.8 - 112.0	27	900	10	1.15	1.5	0.3	89	227	119	55/64	36	2.3	27110
28110	92.3 - 140	28	1200	8	1.20	2.0	0.2	89	227	119	55/64	36	2.3	28110

For standard flange types and recommendations see pages 108 onwards

* Non-adjustable mounting feet