

Agilent L Series **Multiport Electromechanical Coaxial Switches**

L7104A/B/C and L7106A/B/C Terminated
L7204A/B/C and L7206A/B/C Unterminated
DC to 4 GHz, DC to 20 GHz, DC to 26.5 GHz

Technical Overview

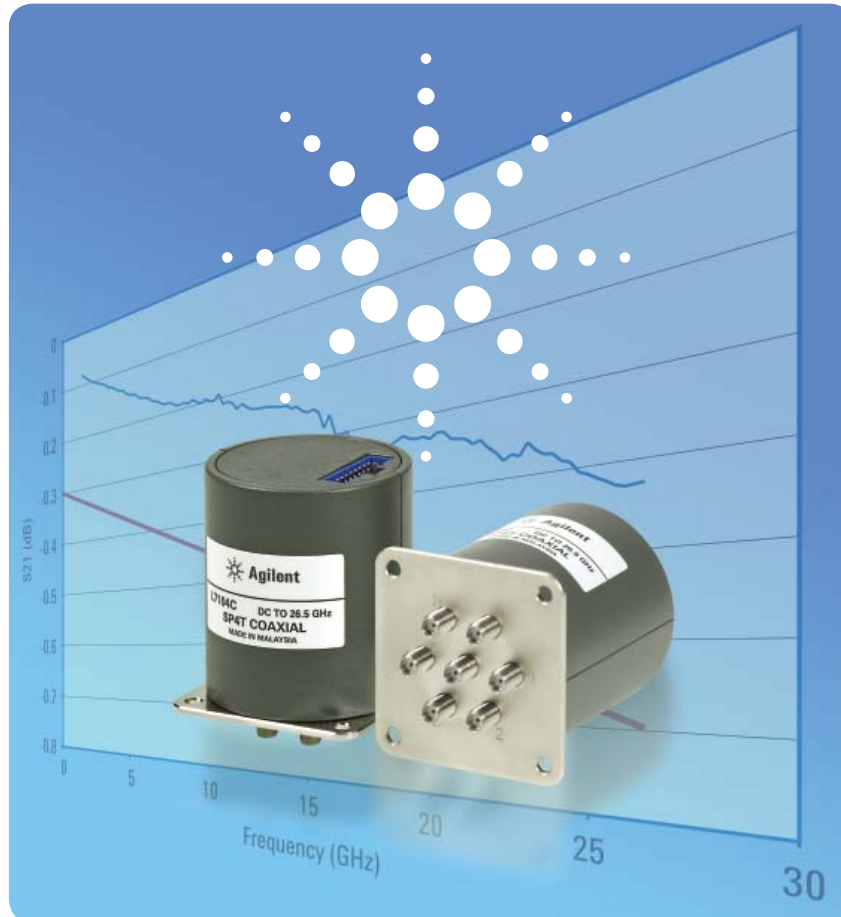

High-performance multiport switches at an affordable price

- Guaranteed 0.03 dB repeatability ensures accuracy and reduces calibration cycles for the entire 2 million cycle operating life.
- Unmatched isolation maximizes measurement accuracy and improves system dynamic range
- Economical price minimizes budgetary constraints

Product Overview

In today's competitive world, automated test systems demand higher accuracy and performance than ever before. The Agilent Technologies L Series L7104A/B/C and L7106A/B/C terminated and L7204A/B/C and L7206A/B/C unterminated, multiport switches offer the improvements in insertion loss repeatability and isolation necessary to achieve higher test system performance. Long life, repeatability, and reliability lower the cost of ownership by reducing calibration cycles and increasing test system uptime and are vital to ATS measurement system integrity over time.

Description

The L7104/L7204A,B,C SP4T and L7106/L7206A,B,C SP6T multiport switches provide the life and reliability required for automated test and measurement, signal monitoring, and routing applications. Innovative design and careful process control creates switches that meet the requirements for highly repeatable switching elements in test instruments and switching interfaces. The exceptional 0.03 dB insertion loss repeatability is warranted for 2 million cycles at 25° C. This reduces sources of random errors in the measurement path and improves measurement uncertainty. Switch life is a critical consideration in production test systems, satellite and antenna monitoring systems, and test instrumentation. The longevity of these switches increases system uptime, and lowers the cost of ownership by reducing calibration cycles and switch maintenance.

High-performance multiport switches for microwave and RF instrumentation and systems

- SP4T and SP6T configuration
- Magnetic latching
- Warranted 0.03 dB insertion loss repeatability for 2 million cycles
- Excellent isolation, typically > 85 dB at 26.5 GHz
- Opto-electronic indicators and interrupts
- Terminated and unterminated ports
- TTL/5 V CMOS compatible (optional)

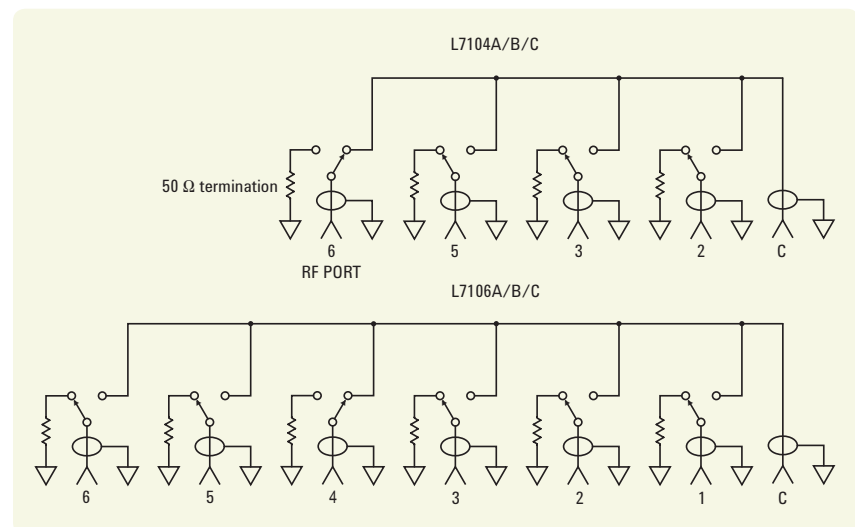

Figure 1. Agilent L7104A/B/C and L7106A/B/C simplified schematics

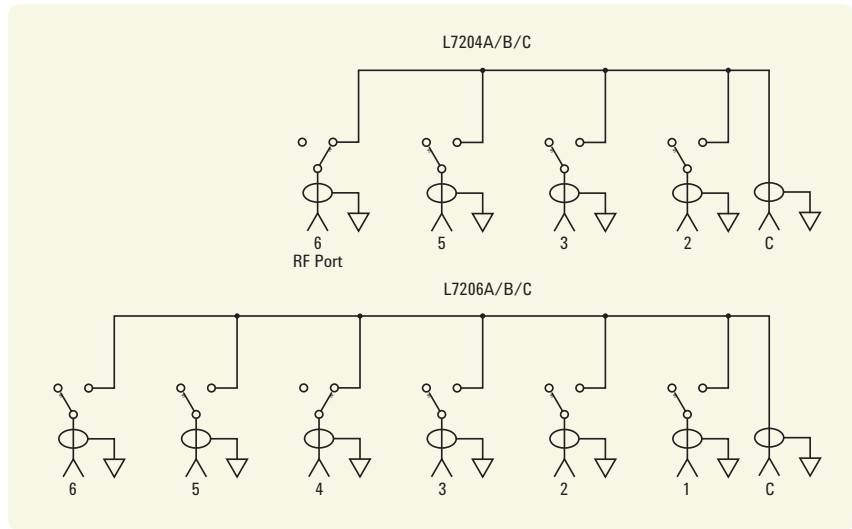

Figure 2. Agilent L7204A/B/C and L7206A/B/C unterminated simplified schematics

Operating up to 4 GHz (A models), 20 GHz (B models), and 26.5 GHz (C models), these switches exhibit the exceptional isolation performance required to maintain measurement integrity. Isolation between ports is typically > 90 dB to 12 GHz and > 85 dB to 26.5 GHz. This reduces the influence of signals from other channels, sustains the integrity of the measured signal, and reduces system measurement uncertainties. These switches also minimize measurement uncertainty with low insertion loss and reflection, which make them ideal elements in large multitiered switching systems.

All the L7104/L7204A,B,C and L7106/L7206A,B,C are designed to fall within most popular industry footprints. The 2¼ inch square flange provides mounting holes, while the rest of the 2½ inch long by 2¼ inch diameter body will easily fit into most systems. Ribbon cable or optional solder terminal connections accommodate the need for secure and efficient control cable attachment

Option 100 provides solder terminal connections in place of the 16-pin ribbon drive cable. Option 100 does not incorporate the “open all paths” feature.

Opto-electronic interrupts and indicators improve reliability and extend the life of the switch by eliminating DC circuit contact failures characteristic of conventional electromechanical switches. These switches have an interrupt circuit that provides logic to open all but the selected ports, it then closes the selected ports cutting off the current to the solenoids of the ports. These switches also offer independent indicators that are controlled by optical interrupts in the switch. The indicators provide a closed path between the indicator common pin and the corresponding sense pin of the selected path.

Applications

Multiport switches find use in a large number of applications, increasing system flexibility and simplifying system design.

Signal routing

The simplest signal routing scheme takes the form of single input to multiple outputs. These matrixes are often used on the front of an analyzer to test several two-port devices sequentially or to test multiport devices. In surveillance applications, a multiport switch can be used to select the optimum antenna for intercepting a signal. Two methods can be used to accomplish the single input to multiple output arrangement. Traditionally where isolation greater than 60 dB was required, a tree matrix composed of SPDT switches was used. While this gave great isolation, it was at the cost of more switches (Figure 3). These switches have port-to-port isolations typically greater than 85 dB at 26.5 GHz, eliminating the need to use a tree matrix in order to achieve high isolation (Figure 4). In addition to the reduced part count, the path lengths are shorter, so insertion loss is less, and paths are of equal length, so phase shift is constant.

Full access switching

Full access switching systems give the flexibility to route multiple input signals to multiple outputs simultaneously. Full access switching matrixes are used in generic test systems in order to provide flexible routing of signals to and from many different devices under test, and stimulus and analysis instrumentation. Cross-point matrixes, using single pole double throw and cross-point switches, have traditionally been used in order to maintain high channel-to-channel isolation (Figure 5). As with the tree matrixes, this is at the cost of hardware and performance. Full access switching can also be achieved using multiport switches (Figure 6).

The advantage of the multiport matrix over the cross-point matrix is lower insertion loss and improved SWR performance due to consistent path length and fewer switches and connecting cables.

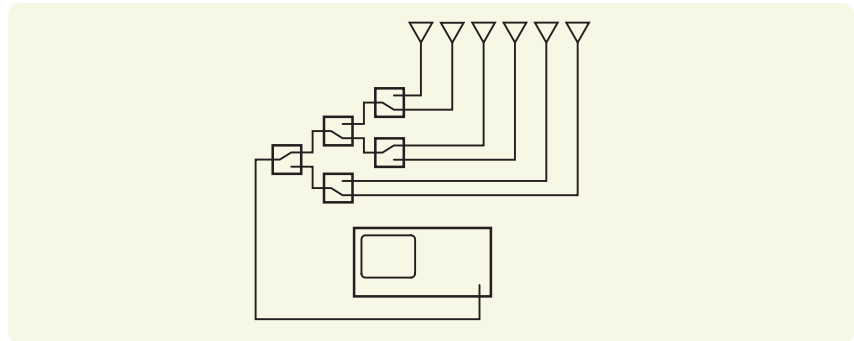

Figure 3. Tree matrix

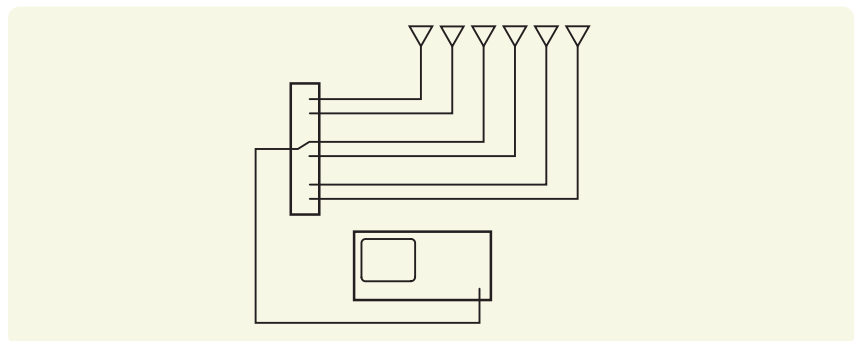

Figure 4. Multiport matrix

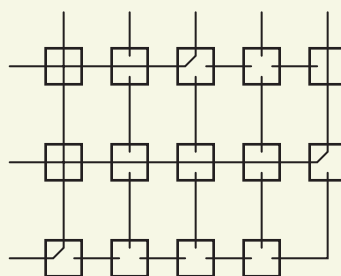

Figure 5. Cross-point matrix

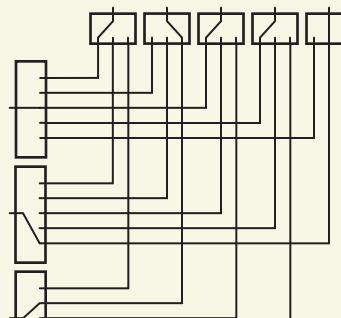

Figure 6. Full access matrix

Dedicated switching

There are a number of applications where switching is used, not for flexibility, but to accomplish a particular function within an instrument. For example, switched filter banks for reducing harmonics in the output of sources or to the input of analyzers can use multiport switches in series to select the right filter for the band of interest. For larger switching systems, where many switches are used to provide complex signal routing, a switch driver such as the Agilent 11713A with L7104/6 or L7204/6 switches is recommended.

Driving the switch

Each RF path can be closed by applying ground (TTL “High” for Option T24) to the corresponding “drive” pin. In general, all other RF paths are simultaneously opened by internal logic.

Standard drive

See Figure 11 for drive connection diagrams.

- Connect pin 1 to supply (+20 VDC to +32 VDC)
- Connect pin 15 to ground (see Note 1).
- Select (close) desired RF path by applying ground to the corresponding “drive” pin; for example ground pin 3 to close RF path 1 (see Note 2).
- To select another RF path, ensure that all unwanted RF path “drive” pins are disconnected from ground (to prevent multiple RF path engagement). Ground the “drive” pin which corresponds to the desired RF path (see Note 3).
- To open all RF paths, ensure that all RF path “drive” pins are disconnected from ground. Then, connect pin 16 to ground. This feature is not available with Option 100.

TTL drive (Option T24)

See Figure 11 for drive connection diagrams.

- Connect pin 1 to supply (+20 VDC to +32 VDC)
- Connect pin 15 to ground (see Notes 1, 4).
- Select (close) desired RF path by applying TTL “High” to the corresponding “drive” pin; for example apply TTL “High” to pin 3 to close RF path 1 (see Note 2).
- To select another path, ensure that all unwanted RF path “drive” pins are at TTL “Low” (to prevent multiple RF path engagement). Apply TTL “High” to the “drive” pin which corresponds to the desired RF path (see Note 3).
- To open all RF paths, ensure that all RF path “drive” pins are at TTL “Low.” Then, apply TTL “High” to pin 16. This feature is not available with Option 100.

Notes:

1. Pin 15 must always be connected to ground to enable the electronic position-indicating circuitry and drive logic circuitry.

CAUTION: IF PIN 15 IS NOT CONNECTED TO POWER SUPPLY GROUND, CATASTROPHIC FAILURE WILL OCCUR.

2. After the RF path is switched and latched, the drive current is interrupted by the electronic position-sensing circuitry. Pulsed control is not necessary, but if implemented, the pulse width must be 15 ms minimum to ensure that the switch is fully latched.
3. The default operation of the switch is break-before-make. Make-before-break switching can be accomplished by simultaneously selecting the old RF path “drive” pin and the new RF path “drive” pin. This will simultaneously close the old RF path and the new RF path. Once the new RF path is closed (15 ms), de-select the old RF path “drive” pin while leaving the new RF path “drive” pin selected. The switch circuitry will automatically open the old RF path while leaving the new RF path engaged.
4. In addition to the quiescent current supplying the electronic position-sensing circuitry, the drive current flows out of pin 15 (during switching) on TTL drive switches (Option T24).

Electronic position indicators

The electronic position indicators consist of optically isolated, solid-state relays which are driven by photo-electric sensors coupled to the mechanical position of the RF path’s moving elements (Figure 7). The circuitry consists of a common which can be connected to an output corresponding to each RF path. If multiple RF paths are engaged, the position indicator corresponding to each closed RF path will be connected to common. The solid state relays are configured for AC and/or DC operation. (See indicator specifications on page 8.) The electronic position indicators require that the supply (20 to 32 VDC) be connected to pin 1 and ground connected to pin 15.

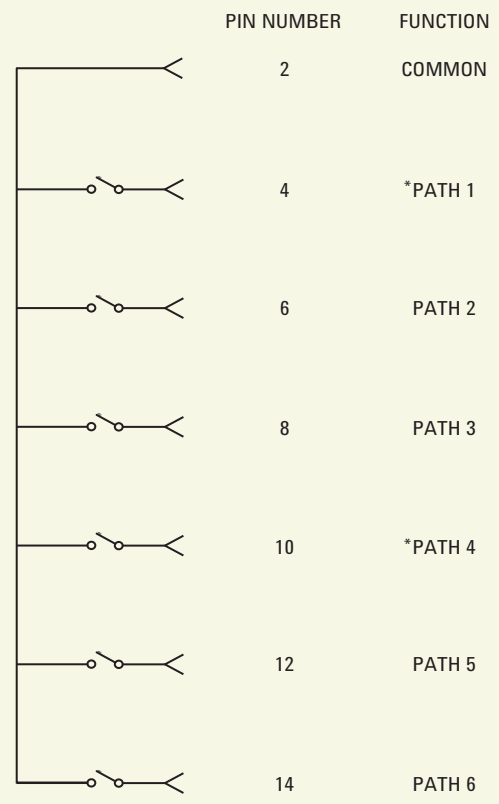

* Paths 1 and 4 are not connected for the L7104A/B/C and L7204A/B/C

Figure 7. Pin function diagram

Specifications

Specifications describe the instrument's warranted performance. *Supplemental* and *typical characteristics* are intended to provide information useful in applying the instrument by giving typical, but not warranted performance parameters.

| | |
|------------------------------|---|
| Maximum power rating: | 1 W average into 50 Ω internal loads |
| Switching: | 1 W CW for terminated 2 W CW for unterminated |
| Non-switching: | 50 W Pk (not to exceed 1 watt average) for terminated 100 W Pk (not to exceed 2 watt average) for unterminated |
| Life: | 2,000,000 cycles minimum |
| Switching speed: | 15 ms maximum |

Reference conditions:

- Cold switching only (NO Hot switching)
- Ambient temperature of 75°C or less
- Sea level (0.88 derating at 15,000ft.)
- Load VSWR < 1.2 (see graph for derating above 1.2 VSWR)
- Power handling at 25°C is 100 W at 4 GHz

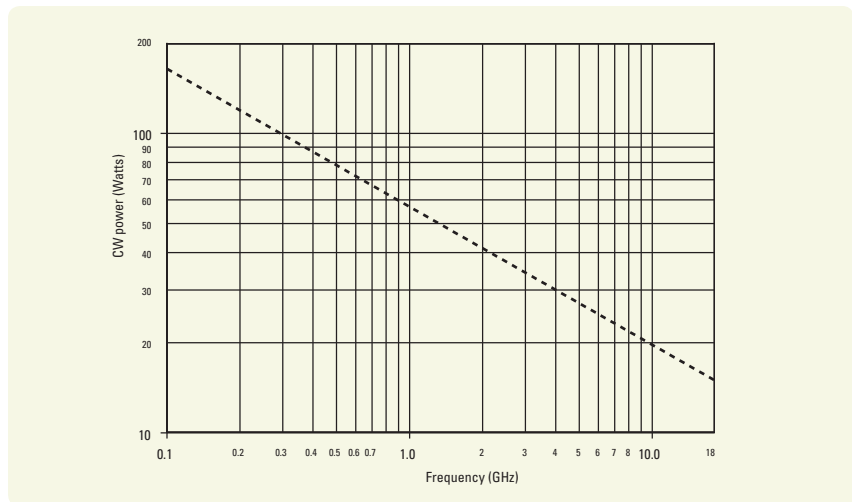

Figure 8. Power rating for cold switching at 75 °C

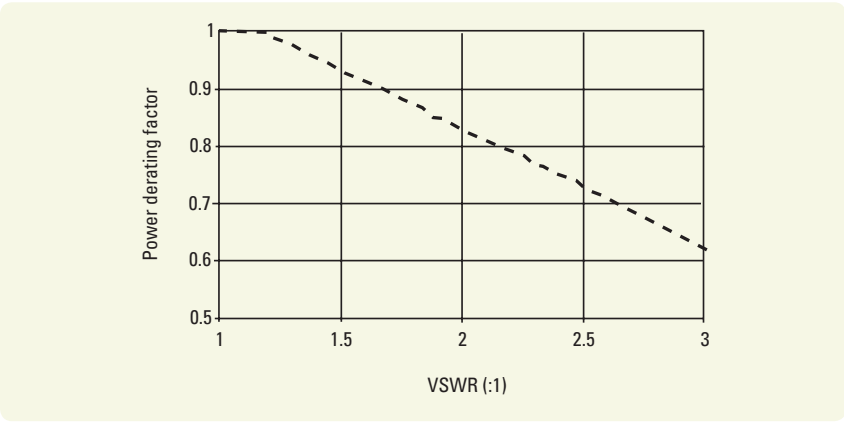

Figure 9. Power derating factor versus VSWR

Indicator specifications:

- Maximum withstand voltage:** 60 V
- Maximum current capacity:** 150 mA
- Maximum "ON" resistance:** 2.5 Ω
- Maximum "OFF" resistance:** 10 G Ω

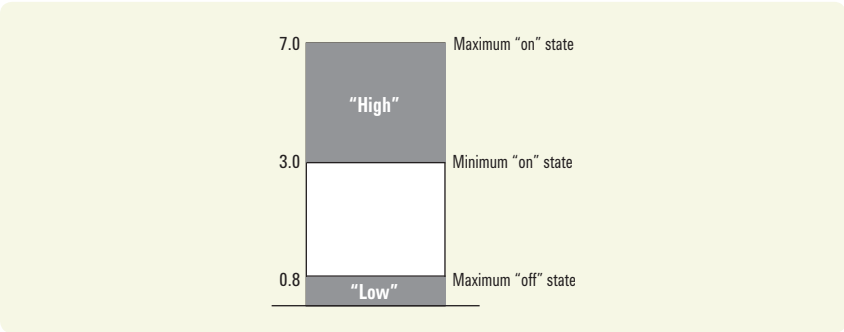

Figure 10. TTL control voltage states (Option T24)

Switch drive specifications

| Parameter test | Conditions | Min | Nom | Max | Units |
|------------------------------------|--|------------|------------------|------------|-------------|
| Supply voltage, Vcc | | | | | |
| STD, Option T24 | | 20 | 24 | 32 | V |
| Supply current, Icc | Switching pulse width $\geq 15\text{ms}$:Vcc =24 VDC ¹ | | | | |
| STD Option T24 | | | 200 ¹ | | mA |
| Supply current, (quiescent) | | | | | |
| STD, Option T24 | | 25 | | 50 | mA |
| Option T24 | | Min | Nom | Max | Unit |
| High level input | | 3 | | 7 | V |
| Low level input | | | | 0.8 | V |
| Max high input current | Vcc=Max Vinput=3.85 VDC | | 1 | 1.4 | mA |

1. Closing one RF path requires 200 mA. Add 200 mA for each additional RF path closed or open. Using all RF paths open (selecting pin 16) requires 200 mA per RF path reset with Vcc=24 VDC.

| | L7104A/L7204A L7106A/L7206A | L7104B/L7204B L7106B/L7206B | L7104C/L7204C L7106C/L7206C |
|--|--|--|--|
| Frequency range | DC to 4 GHz | DC to 20 GHz | DC to 26.5 Hz |
| Insertion loss (see Figure 7) | 0.3 dB + 0.015 x frequency (GHz) | 0.3 dB + 0.015 x frequency (GHz) | 0.3 dB + 0.015 x frequency (GHz) |
| Isolation (see Figure 8) | 90 dB minimum DC | 90 dB minimum DC to 12 GHz 70 dB minimum, 12 GHz to 15 GHz 65 dB minimum, 15 to 20 GHz | 90 dB minimum to 12 GHz 70 dB minimum, 12 GHz to 15 GHz 65 dB minimum, 15 to 20 GHz 60 dB minimum, 20 to 26.5 GHz |
| SWR | 1.2 maximum | 1.2 maximum, DC to 4 GHz 1.35 maximum, 4 to 12.4 GHz 1.45 maximum, 12.4 to 18 GHz 1.7 maximum, 18 to 26.5 GHz | 1.2 maximum, DC to 4 GHz 1.35 maximum, 4 to 12.4 GHz 1.45 maximum, 12.4 to 18 GHz 1.7 maximum, 18 to 26.5 GHz |
| Repeatability (Up to 2 million cycles measured at 25° C) | 0.03 dB maximum | 0.03 dB maximum | 0.03 dB maximum |
| Connectors | SMA (f) | SMA (f) | SMA (f) |

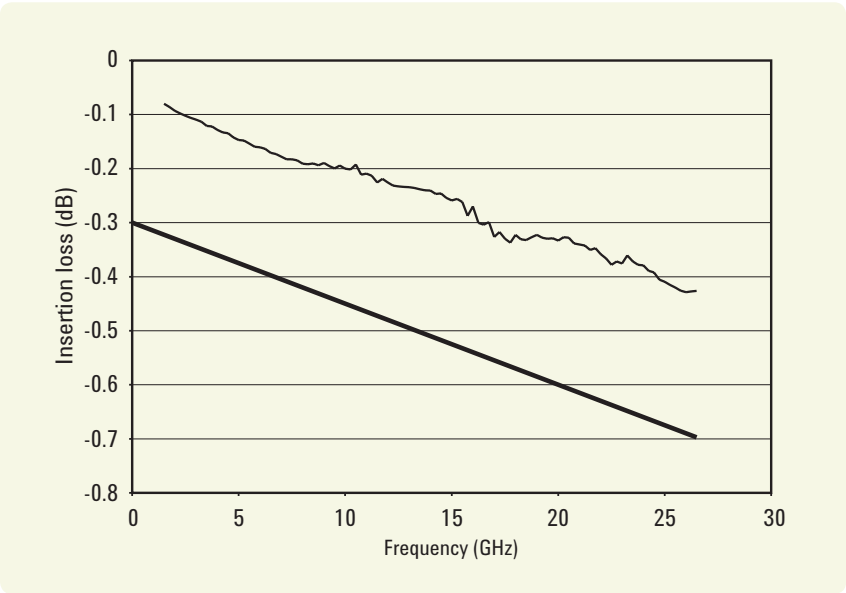

Figure 11. Agilent L Series multipoint switch insertion loss versus frequency

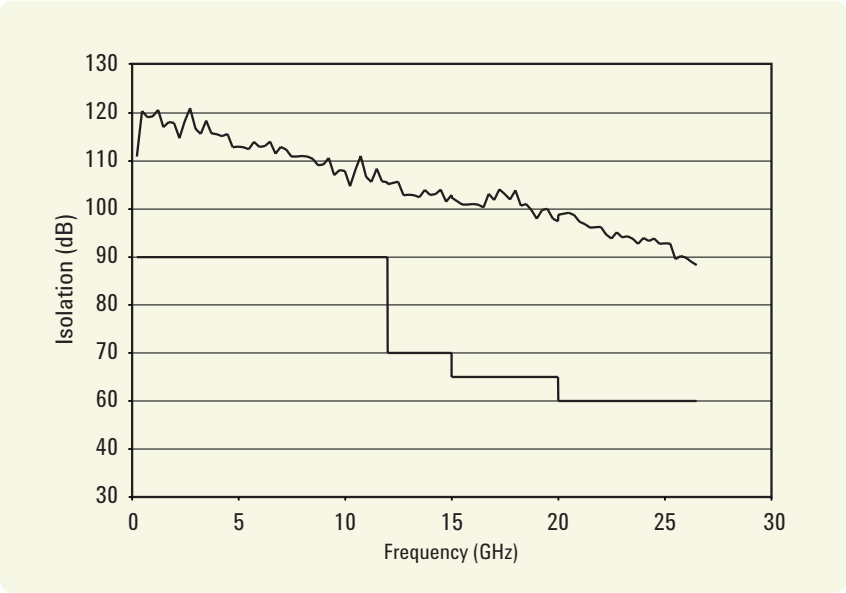

Figure 12. Agilent L Series multipoint switch isolation versus frequency

Environmental specifications

| | |
|-------------------------------|---|
| Operating temperature: | –25 to 75°C |
| Storage temperature: | –55 to 85°C |
| Temperature cycling: | –55 to 85°C, 10 cycles per MIL-STD-202F, Method 107D, Condition A (modified) |
| Vibration: | Operating: 7 g; 5 to 2000 Hz at 0.25 in p-p Survival: 20 g; 20 to 2000 Hz at 0.06 in p-p, 4 min/cycle, 4 cycles/axis Random: 2.41 g (rms) 10 min/axis |
| Shock: | Half-sine: 500 g at 0.5 ms, 3 drops/direction, 18 total |
| Operating: | 50 g at 6 ms, 6 directions |
| Moisture resistance: | 65°C, 95% RH, 10 days per MIL-STD-202F, Method 106E |
| Altitude storage: | 50,000 feet (15,240 meters per MIL-STD-202F, Method 105C, Condition B) |
| RFI: | Radiated Emission per CISPR 11 |
| Magnetic field: | < 5 gauss ¼ inch from surface |

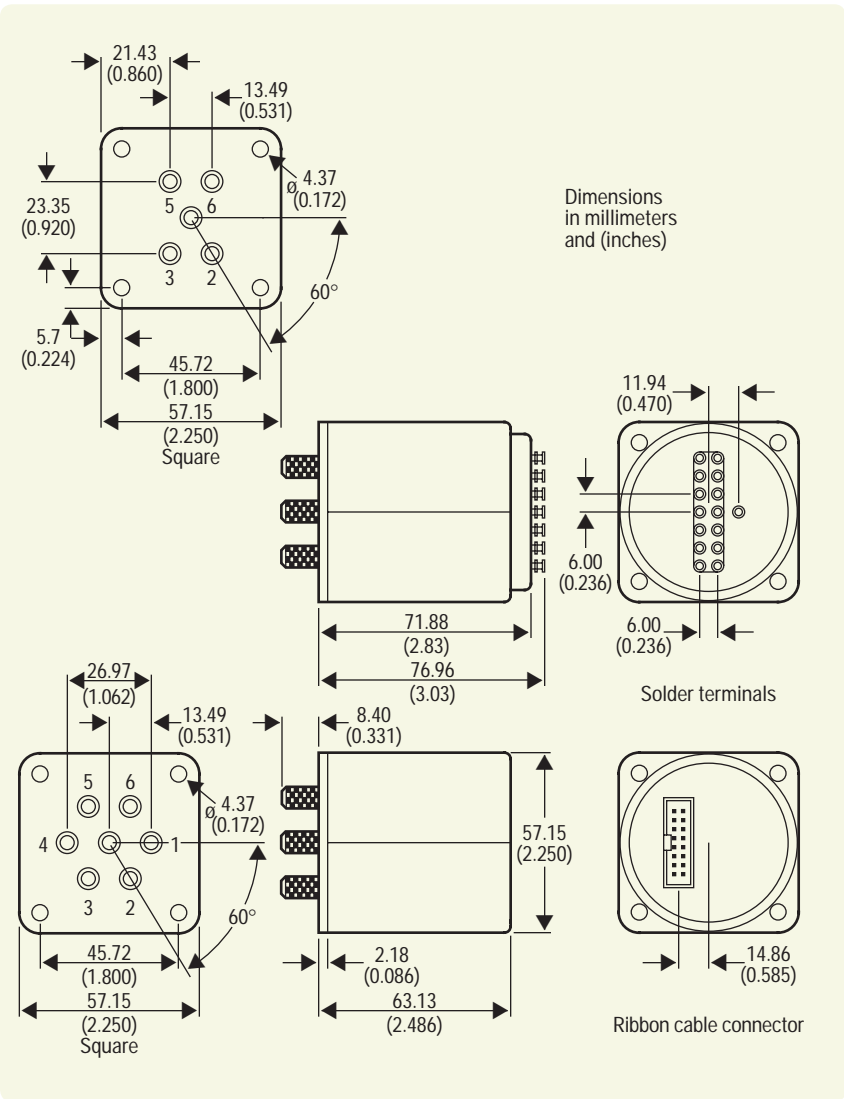

Figure 13. Product dimensions for L7104/106 A,B,C and L7204/206 A,B,C

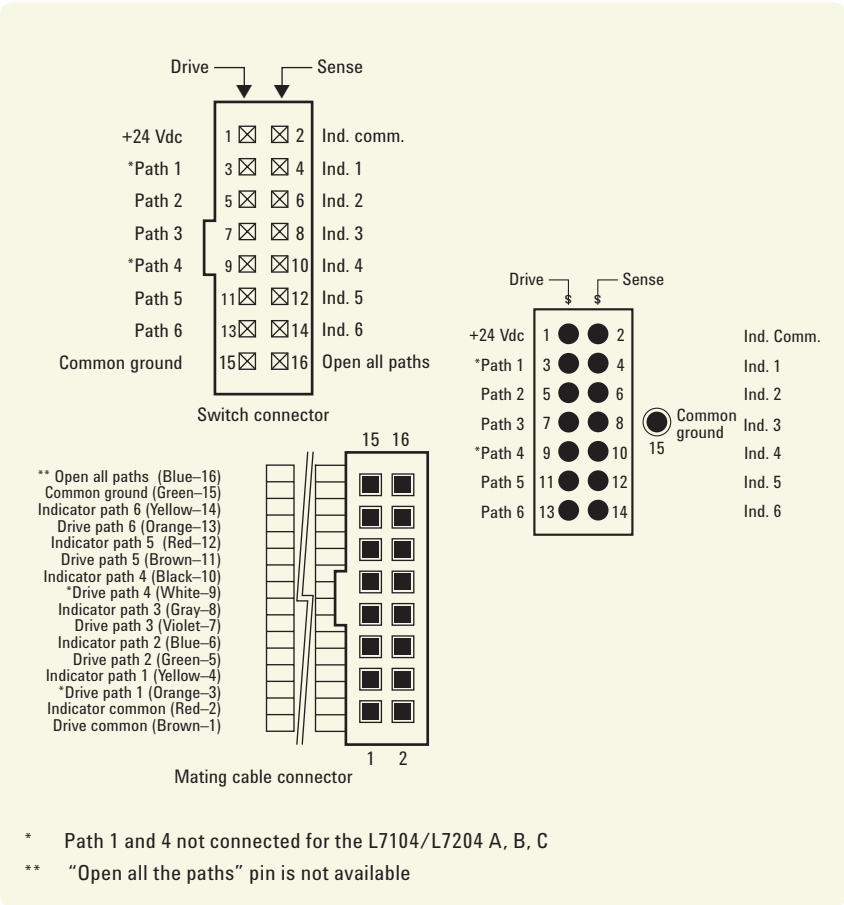

Figure 14. Drive connection diagrams with Option 100

Troubleshooting

| Symptom | Probable cause |
|------------------------------------|--|
| 1. Will not switch | <ul style="list-style-type: none"> • Not connected to supply • Supply < 20 V • Supply current too low • Not connected to ground • Select line not at ground (std) • TTL "Low" voltage too high (Option 72) • All-path-open line selected |
| 2. Position indicators do not work | <ul style="list-style-type: none"> • Supply not connected • Supply < 20 VDC • Pin 15 not connected to ground |

Ordering information

Switches

| | |
|-------------------|---|
| L7104A | DC to 4 GHz, SP4T Terminated |
| L7104B | DC to 20 GHz, SP4T Terminated |
| L7104C | DC to 26.5 GHz, SP4T Terminated |
| L7204A | DC to 4 GHz, SP4T Unterminated |
| L7204B | DC to 20 GHz, SP4T Unterminated |
| L7204C | DC to 26.5 GHz, SP4T Unterminated |
| L7106A | DC to 4 GHz, SP6T Terminated |
| L7106B | DC to 20 GHz, SP6T Terminated |
| L7106C | DC to 26.5 GHz, SP6T Terminated |
| L7206A | DC to 4 GHz, SP6T Unterminated |
| L7206B | DC to 20 GHz, SP6T Unterminated |
| L7206C | DC to 26.5 GHz, SP6T Unterminated |
| Option 100 | Solder terminals to replace ribbon cable |
| Option UK6 | Commercial calibration test data with certificate |
| Option T24 | TTL/5 V CMOS compatible option |

Drivers

11713A Attenuator switch driver

Drives up to 10 sections of switches or attenuators.

5061-0969 Accessory cable

Viking connector to bare tinned wires (60 inches long). Use to connect 11713A to L7104/204/106/206 with Option 100. One required with L7104/L7204 Option 100; two required with L7106/L7206 Option 100.

Configuration guide

See publication 5963-2038E.

For more information on test accessories go to:
www.agilent.com/find/mta



Agilent Email Updates

www.agilent.com/find/emailupdates
Get the latest information on the products and applications you select.



Agilent Direct

www.agilent.com/find/agilentdirect
Quickly choose and use your test equipment solutions with confidence.

Remove all doubt

Our repair and calibration services will get your equipment back to you, performing like new, when promised. You will get full value out of your Agilent equipment throughout its lifetime. Your equipment will be serviced by Agilent-trained technicians using the latest factory calibration procedures, automated repair diagnostics and genuine parts. You will always have the utmost confidence in your measurements.

Agilent offers a wide range of additional expert test and measurement services for your equipment, including initial start-up assistance onsite education and training, as well as design, system integration, and project management.

For more information on repair and calibration services, go to

www.agilent.com/find/removealldoubt

www.agilent.com

For more information on Agilent Technologies' products, applications or services, please contact your local Agilent office. The complete list is available at:

www.agilent.com/find/contactus

Phone or Fax

United States:
(tel) 800 829 4444
(fax) 800 829 4433

Canada:
(tel) 877 894 4414
(fax) 800 746 4866

China:
(tel) 800 810 0189
(fax) 800 820 2816

Europe:
(tel) 31 20 547 2111

Japan:
(tel) (81) 426 56 7832
(fax) (81) 426 56 7840

Korea:
(tel) (080) 769 0800
(fax) (080) 769 0900

Latin America:
(tel) (305) 269 7500

Taiwan:
(tel) 0800 047 866
(fax) 0800 286 331

Other Asia Pacific Countries:
(tel) (65) 6375 8100
(fax) (65) 6755 0042
Email: tm_ap@agilent.com
Revised: 2/07

Product specifications and descriptions in this document subject to change without notice.

© Agilent Technologies, Inc. 2007
Printed in USA, March 2, 2007
5989-6030EN



Agilent Technologies