

7053

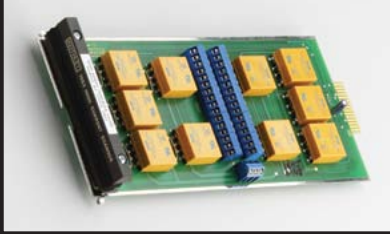

- 5A switching
- 10-channel scanner
- 2-pole Form A
- Maintains current path for unselected channel

Ordering Information

7053 10-channel High Current Scanner with Screw Terminal Connections

7067

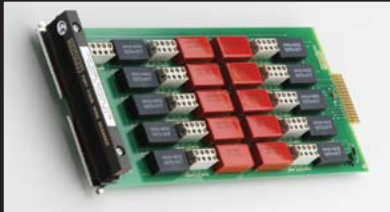

- $1\mu\text{V}$ contact potential
- 4-pole Form A relays
- Quick disconnect screw terminal connections

Ordering Information

7067 4-Wire Scanner Card with Screw Terminal Connections

High Current Scanner Card

10-channel, 2-Pole

The Model 7053 has ten channels and features 5A contacts. The switching is designed to maintain current paths for signals not connected to the output or, when internal jumpers are removed, to provide high input resistance for making voltage measurements. Semiconductor testing, materials research, power supply testing, solar cell measurements, electrochemical applications, and IC testing are among the applications simplified with the Model 7053 High Current Scanner Card.

CHANNELS PER CARD: 10.

CONTACT CONFIGURATION: 2-pole Form A with common guard.

CONNECTOR TYPE: Screw terminal, #18AWG maximum wire size.

RELAY DRIVE CURRENT: 80mA per relay typical.

MAXIMUM SIGNAL LEVEL: 300V, 5A, 100VA (resistive load only).

CONTACT LIFE: $>10^7$ closures cold switching; $>10^5$ closures at maximum signal levels.

CONTACT RESISTANCE: $<0.15\Omega$ to rated life.

CONTACT POTENTIAL: $<1\text{mV}$.

ACTUATION TIME: $<15\text{ms}$, exclusive of mainframe.

CHANNEL ISOLATION: $>10^6\Omega$, $<50\text{pF}$.

INPUT ISOLATION: $>10^7\Omega$, $<150\text{pF}$.

COMMON MODE VOLTAGE: 300V peak.

EMC: Conforms to European Union Directive 89/336/EEC.

SAFETY: Conforms to European Union Directive 73/23/EEC (meets EN61010-1/IEC 1010).

OPERATING ENVIRONMENT: 0° to 50°C , up to 35°C at 70% RH.

STORAGE ENVIRONMENT: -25°C to 65°C .

SERVICES AVAILABLE

7053-3Y-EW 1-year factory warranty extended to 3 years from date of shipment

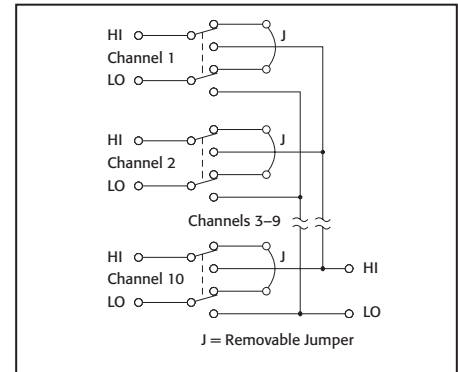

4-Wire Scanner Card

10-channel

Four-wire or Kelvin connections are generally made to minimize errors created by I-R drops in the cabling and interconnects of a test system. Each channel of the Model 7067 has two general-purpose source contacts that switch currents up to 350mA, as well as two high quality contacts ($<1\mu\text{V}$ contact potential) for dry switching of voltage to the sensing circuit. The Model 7067 is well-suited to precision resistance measurements as required in temperature coefficient testing. Other applications include remote sensing of voltage source outputs and bridge measurements.

CHANNELS PER CARD: 10.

CONTACT CONFIGURATION: 4-pole Form A, common shield connection.

RELAY DRIVE CURRENT: 35mA per channel typical.

SENSE LINES:

Maximum Signal Level: 150V, 100mA, 2VA (resistive loads only).

Contact Resistance: $<0.5\Omega$ initial, 2Ω to rated life.

Contact Potential: $<1\mu\text{V}$ per contact pair with copper leads (<5 minutes after actuation).

SOURCE LINES:

Maximum Signal Level: 150V, 350mA, 10VA (resistive loads only).

Contact Resistance: $<0.2\Omega$ initial, 2Ω to rated life.

Contact Potential: $<100\mu\text{V}$ per contact pair.

CONNECTOR TYPE: Quick disconnect screw terminal, #18AWG maximum wire size.

CONTACT LIFE: $>10^8$ closures at dry circuit; $>10^6$ closures at maximum signal levels.

WARM-UP: 1 hour for thermal stability.

ACTUATION TIME: $<2\text{ms}$, exclusive of mainframe.

CHANNEL ISOLATION: $>10^6\Omega$, $<10\text{pF}$.

INPUT ISOLATION, DIFFERENTIAL: $>10^6\Omega$, $<50\text{pF}$.

COMMON MODE VOLTAGE: $<150\text{V}$ peak.

OPERATING ENVIRONMENT: 0° to 50°C , up to 35°C at 70% R.H.

STORAGE ENVIRONMENT: -25°C to 65°C .

APPLICATIONS: 4-wire resistance (resistors, relays, connectors, switches, RTDs). External sensing on voltage sources. DUT in/out switching (potentiometers, isolation amplifiers, strain gages).

SERVICES AVAILABLE

7067-3Y-EW 1-year factory warranty extended to 3 years from date of shipment

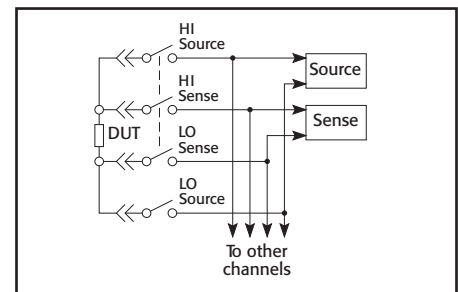

1.888.KEITHLEY (U.S. only)
www.keithley.com

KEITHLEY