

# System 46

## RF/Microwave Switch System

32-channel, Unterminated



- Compact RF/microwave switching system only 2U high
- Built-in contact closure counter to monitor switch cycles
- Standard configuration allows up to 32 channels of switching
- Simple control with built-in GPIB/IEEE-488 interface bus
- Channel characterization data storage
- Frequency ranges up to 40GHz

### APPLICATIONS

- Cellular and cordless phones
- Specialized mobile radios
- Base stations
- Specialized antenna systems
- RF components, including RFICs
- Wireless peripherals, including Bluetooth devices
- Broadband wireless transceivers
- High speed digital communications, including SONET speeds 3Gbps and 10Gbps

### Flexible Solutions in a Compact Package

The S46 Microwave Switch System is designed to simplify the automated switching needed to test a wide range of telecommunications products and devices. The S46 can control 32 relay contacts in a package as small as a 2U high (3.5 in) full-rack enclosure. Standard configurations make it simple to select a system that meets the specifications of the testing application without the expense of unnecessary switches or other features. This "just what you need and no more" design philosophy allows S46 systems to provide outstanding price/performance value.

The enclosures used in standard S46 configurations can accommodate eight SPDT unterminated coaxial microwave relays and four multi-pole, unterminated, coaxial microwave relays. Any of these multi-pole unterminated relays can be one of the following relay types: SP4T or SP6T. S46 switching systems can be used as multiplexers, matrices, independent relays, or a combination of configurations. To order a standard system, simply select the number of relays and their location on the front panel. As test requirements change, relays can be easily added to the system to create a new switch configuration.

### Frequency Range

To accommodate the rapidly evolving test requirements in RF/microwave applications, the S46 has ordering provisions for frequency ranges up to 40GHz. Configuration options include DC to 18GHz, DC to 26.5GHz, and DC to 40GHz.

### Simple Operation

The S46 switch system's 32 control channels can be operated via the IEEE-488 interface bus with a minimal set of instructions. This small instruction set ensures the system can be set up and running quickly. Front panel LEDs indicate the status of all relay contacts continuously to allow the user to monitor system operation easily.

### Excellent Microwave Switching Performance

Keithley's experience and partnerships with leading manufacturers in the microwave relay industry allow Keithley to offer the lowest insertion loss, VSWR, and crosstalk performance specifications available. Low-loss, semi-flexible RF cables are available as accessories to maximize signal integrity.

### Maximum System Up-Time and Enhanced System Performance

The S46 controller automatically counts relay contact closures to allow equipment maintenance personnel to assess when the relays are nearing the end of their mechanical life. In this way, preventive maintenance can be performed in a timely way during scheduled shutdowns, avoiding unplanned shutdowns and the resulting loss of production time.

In addition to counting contact closures, the S46 has a portion of its memory available to store S-parameters or calibration constants for each relay contact or each pathway. If a specific performance parameter is critical, such as Voltage Standing Wave Ratio (VSWR) or insertion loss, the parameter can be stored in memory for use in trend analysis between scheduled maintenance shutdowns. Stored parameters can also be used for compensation to enhance accuracy during RF measurements.

Designed for test applications that require high quality RF/microwave signal routing

SWITCHING AND CONTROL

1.888.KEITHLEY (U.S. only)

[www.keithley.com](http://www.keithley.com)

KEITHLEY

A GREATER MEASURE OF CONFIDENCE

# System 46

## RF/Microwave Switch System 32-channel, Unterminated

### Standard Performance Data of an 18GHz, 1×12 Multiplexer

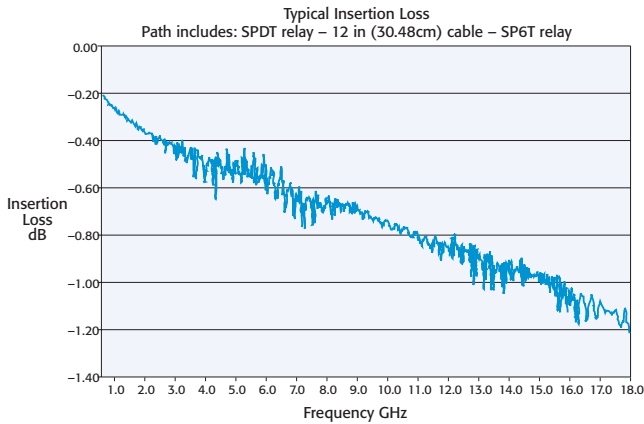
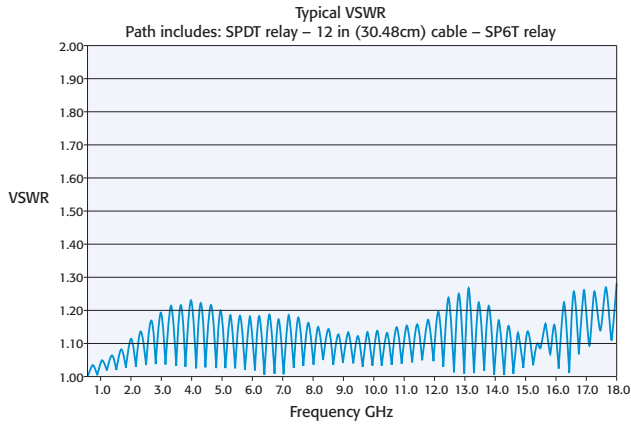

### ACCESSORIES AVAILABLE

#### CABLING

S46-SMA-0.5	DC–18GHz, Low Loss, Semi-Flex SMA-SMA Cable Assembly, 0.152m (6 in.)
S46-SMA-1	DC–18GHz, Low Loss, Semi-Flex SMA-SMA Cable Assembly, 0.305m (12 in.)
S46-SMA-1.7	DC–18GHz, Low Loss, Semi-Flex SMA-SMA Cable Assembly, 0.518m (20.4 in.)
S46-SMA26-0.5	DC–26.5GHz, Low Loss, Semi-Flex SMA-SMA Cable Assembly, 0.152m (6 in.)
S46-SMA26-1	DC–26.5GHz, Low Loss, Semi-Flex SMA-SMA Cable Assembly, 0.305m (12 in.)
S46-SMA26-1.7	DC–26.5GHz, Low Loss, Semi-Flex SMA-SMA Cable Assembly, 0.518m (20.4 in.)
TL-24	SMA Cable Torque Wrench

#### SWITCH KITS

S46-SPDT-KIT	Standard Performance 18GHz Unterminated SPDT Relay and Control Cable Assembly
S46-SP4T-KIT	Standard Performance 18GHz Unterminated SP4T Relay and Control Cable Assembly
S46-SP6T-KIT	Standard Performance 18GHz Unterminated SP6T Relay and Control Cable Assembly
S46-SPDT-KIT-R	High Performance 18GHz Unterminated SPDT Relay and Control Cable Assembly
S46-SP4T-KIT-R	High Performance 18GHz Unterminated SP4T Relay and Control Cable Assembly
S46-SP6T-KIT-R	High Performance 18GHz Unterminated SP6T Relay and Control Cable Assembly
S46-SPDT-KIT-26	High Performance 26.5GHz Unterminated SPDT Relay and Control Cable Assembly
S46-SP4T-KIT-26	High Performance 26.5GHz Unterminated SP4T Relay and Control Cable Assembly
S46-SP6T-KIT-26	High Performance 26.5GHz Unterminated SP6T Relay and Control Cable Assembly
S46-SPDT-KIT-40	High Performance 40GHz Unterminated SPDT Relay and Control Cable Assembly
S46-SP4T-KIT-40	High Performance 40GHz Unterminated SP4T Relay and Control Cable Assembly
S46-SP6T-KIT-40	High Performance 40GHz Unterminated SP6T Relay and Control Cable Assembly

### Examples of Standard System Switch Configurations

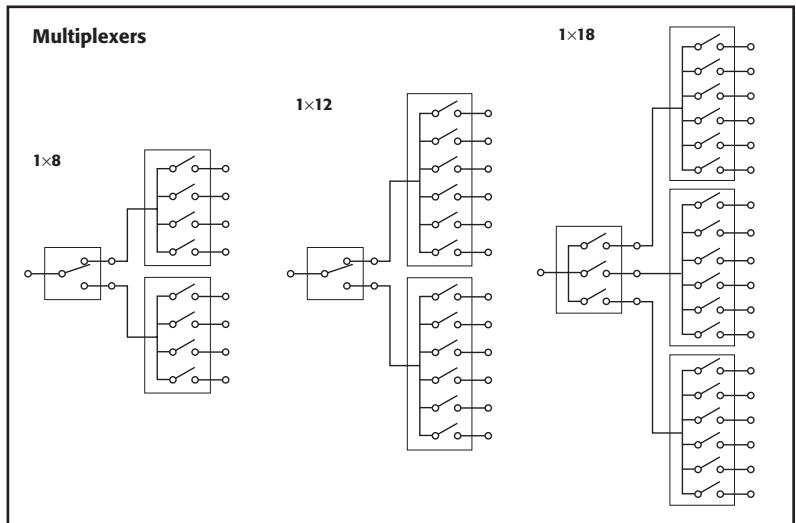
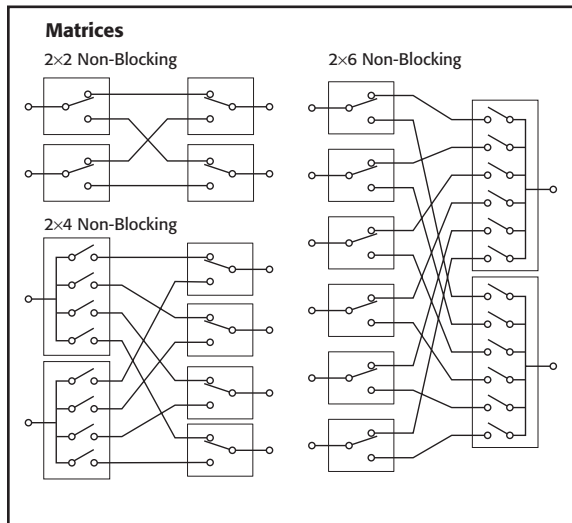

MAXIMUM CONFIGURATION: (8) – Unterminated SPDT relays. (4) – Unterminated multi-pole relays (SP4T, SP6T).

1.888.KEITHLEY (U.S. only)

[www.keithley.com](http://www.keithley.com)

**KEITHLEY**

A GREATER MEASURE OF CONFIDENCE

# System 46

## RF/Microwave Switch System 32-channel, Unterminated

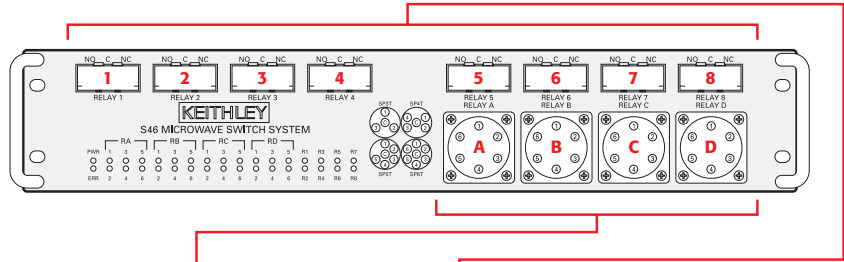

### Ordering Information

Specifying Standard  
S46 Model Numbers



### Accessories Supplied

Power cord, instruction  
manual, and rack mount kit

**S46-**

SP4T or SP6T Relay Locations				SPDT Relay Locations								Frequency Range	
<input type="checkbox"/>	<input type="checkbox"/>	<input type="checkbox"/>	<input type="checkbox"/>	<input type="checkbox"/>	<input type="checkbox"/>	<input type="checkbox"/>	<input type="checkbox"/>	<input type="checkbox"/>	<input type="checkbox"/>	<input type="checkbox"/>	<input type="checkbox"/>	<input type="checkbox"/>	<input type="checkbox"/>
<b>A</b>	<b>B</b>	<b>C</b>	<b>D</b>	<b>1</b>	<b>2</b>	<b>3</b>	<b>4</b>	<b>5</b>	<b>6</b>	<b>7</b>	<b>8</b>		

All four positions must be listed.  
Enter:  
0 = None  
4 = SP4T  
6 = SP6T

Only positions used must be listed.  
Enter:  
1-8 Position Number

Enter:  
Blank = DC-18GHz, Standard Performance  
A = DC-18GHz, High Performance  
B = DC-26.5GHz  
C = DC-40GHz

**Multipole relay locations A-D:** Enter a "4" for an SP4T relay or a "6" for a SP6T relay in the required location. Enter a "0" in unused multi-pole locations. There must be digits in all four positions.

**SPDT relay locations 1-8:** Indicate the position number of all locations where an SPDT switch is required. Only locations used are required.

### Example 1: Model Number S46-0604356

Includes: SP6T in position B, SP4T in position D, SPDTs in positions 3, 5, and 6. Frequency range "Blank," standard performance DC-18GHz.

### Example 2: Model Number S46-0440123B

Includes: SP4T in positions B and C, SPDTs in positions 1, 2, and 3. Frequency range "B," high performance DC-26.5GHz.

### Unterminated Relay Specifications

Option	None	A	B	C
	Std. Performance	High Performance		
FREQUENCY RANGE	DC-18 GHz	DC-18 GHz	DC-26.5 GHz	DC-40 GHz
CONNECTOR TYPE	SPDT SMA	SMA	SMA	SMA 2.9
IMPEDANCE	50Ω	50Ω	50Ω	50Ω
CONTACT LIFE	SPDT 2 × 10 <sup>6</sup> SP4T, SP6T 2 × 10 <sup>6</sup>	1 × 10 <sup>7</sup> 5 × 10 <sup>6</sup>	1 × 10 <sup>7</sup> 2 × 10 <sup>6</sup>	1 × 10 <sup>7</sup> 2 × 10 <sup>6</sup>
VSWR (max.)	DC-6 GHz: 1.25 6-12 GHz: 1.40 12-18 GHz: 1.50	DC-3 GHz: 1.20 3-8 GHz: 1.30 8-12.4 GHz: 1.40 12.4-18 GHz: 1.50	DC-6 GHz: 1.30 6-12.4 GHz: 1.40 12.4-18 GHz: 1.50 18-26.5 GHz: 1.70	DC-6 GHz: 1.30 6-12.4 GHz: 1.40 12.4-18 GHz: 1.50 18-26.5 GHz: 1.70 26.5-40 GHz: 2.20
INSERTION LOSS (max.) dB	DC-6 GHz: 0.2 6-12 GHz: 0.4 12-18 GHz: 0.5	DC-3 GHz: 0.2 3-8 GHz: 0.3 8-12.4 GHz: 0.4 12.4-18 GHz: 0.5	DC-6 GHz: 0.2 6-12.4 GHz: 0.4 12.4-18 GHz: 0.5 18-26.5 GHz: 0.7	DC-6 GHz: 0.2 6-12.4 GHz: 0.4 12.4-18 GHz: 0.5 18-26.5 GHz: 0.7 26.5-40 GHz: 1.1
ISOLATION (min.) dB	DC-6 GHz: 70 6-12 GHz: 60 12-18 GHz: 60	DC-3 GHz: 80 3-8 GHz: 70 8-12.4 GHz: 60 12.4-18 GHz: 60	DC-6 GHz: 70 6-12.4 GHz: 60 12.4-18 GHz: 60 18-26.5 GHz: 55	DC-6 GHz: 70 6-12.4 GHz: 60 12.4-18 GHz: 60 18-26.5 GHz: 55 26.5-40 GHz: 50
ACTUATION TIME (max.) ms	SPDT 20 SP4T, SP6T 15	10 15	10 15	10 15

### GENERAL

**CONTACT CLOSURE COUNTERS:** 1 counter per channel, up to 10 million counts each, maintained in non-volatile memory.

**NON-VOLATILE STORAGE:** 32 separate locations; each location up to 68 bytes long, for user-definable channel and system parameters.

**NUMBER OF RELAY CONTROL LINES:** 32, each open collector driver capable of 300mA sink current (max.).

**INTERFACE:** GPIB (IEEE-488.2) and SCPI.

**INDICATORS:** Power, relay position status, and error LED.

**POWER:** 100-240VAC, 50/60Hz.

**MAXIMUM COMMON MODE:** 42V peak, any terminal to earth.

**ENVIRONMENT:** Operating: 0° to 40°C, up to 35°C < 80% RH. Storage: -25° to 65°C.

**EMC:** Conforms to European Union Directive 89/336/EEC.

**SAFETY:** Conforms with European Union Directive 73/23/EEC.

**DIMENSIONS:** 89mm high × 485mm wide × 370mm. deep (3.5" × 19" × 14.563").

**SHIPPING WEIGHT:** 13kg (28 lbs).

1.888.KEITHLEY (U.S. only)

www.keithley.com

KEITHLEY

A GREATER MEASURE OF CONFIDENCE